

1. 立體圖

立體圖的種類

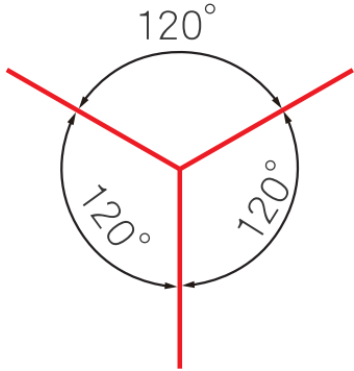

	等角圖	等斜圖
三軸特徵	三軸夾角互為120 度 	有兩軸呈90 度 
圖例		

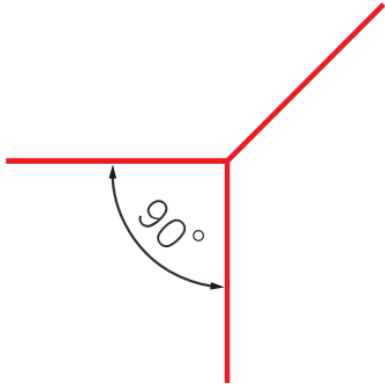
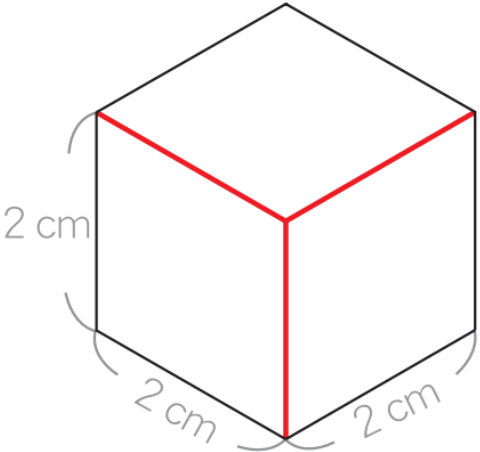
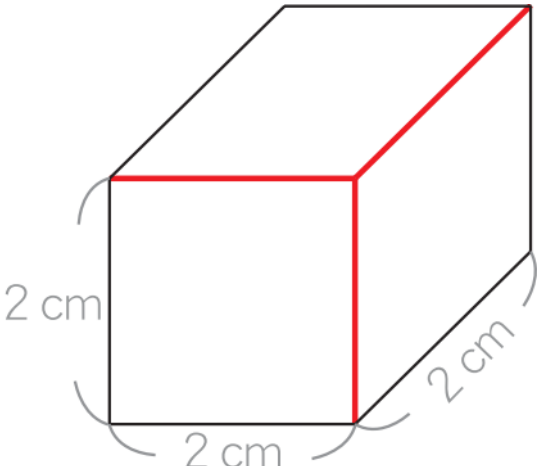
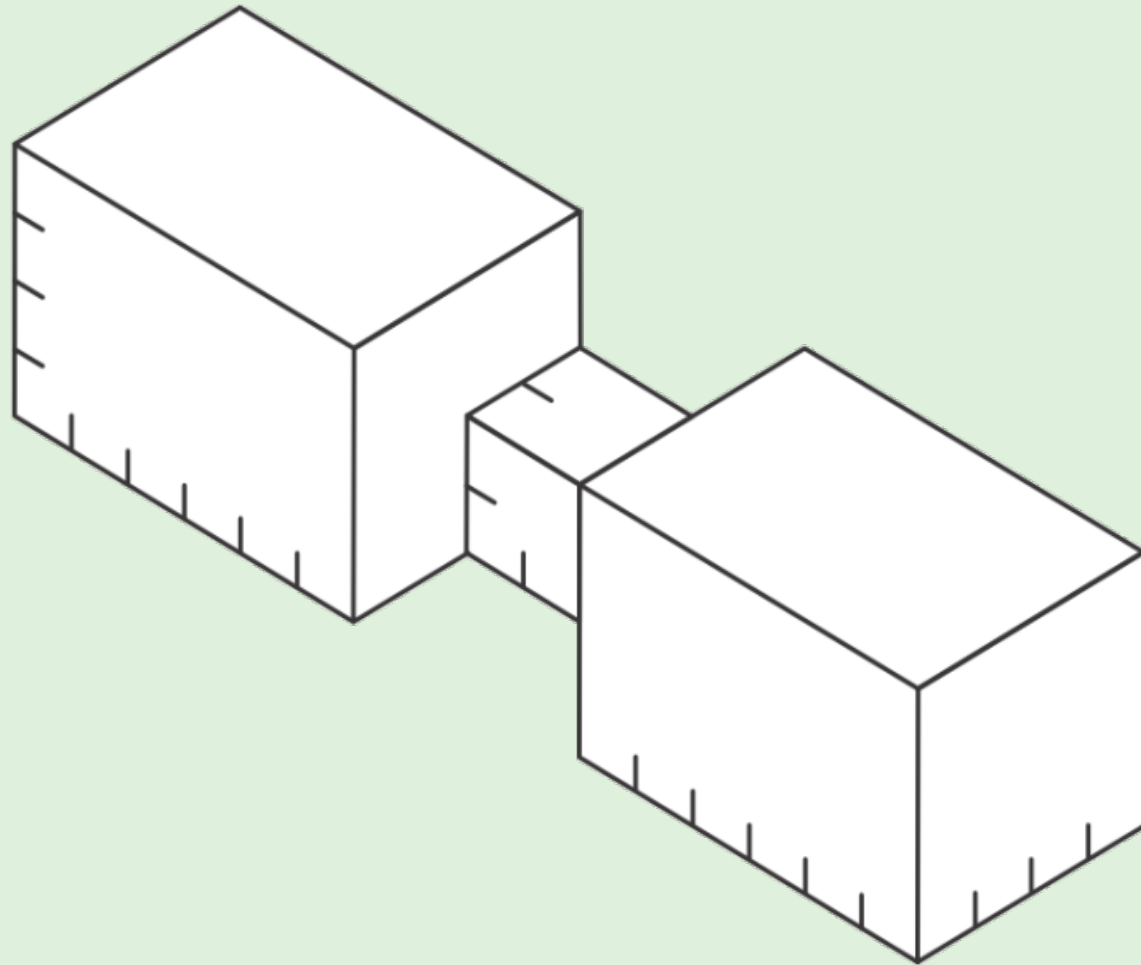

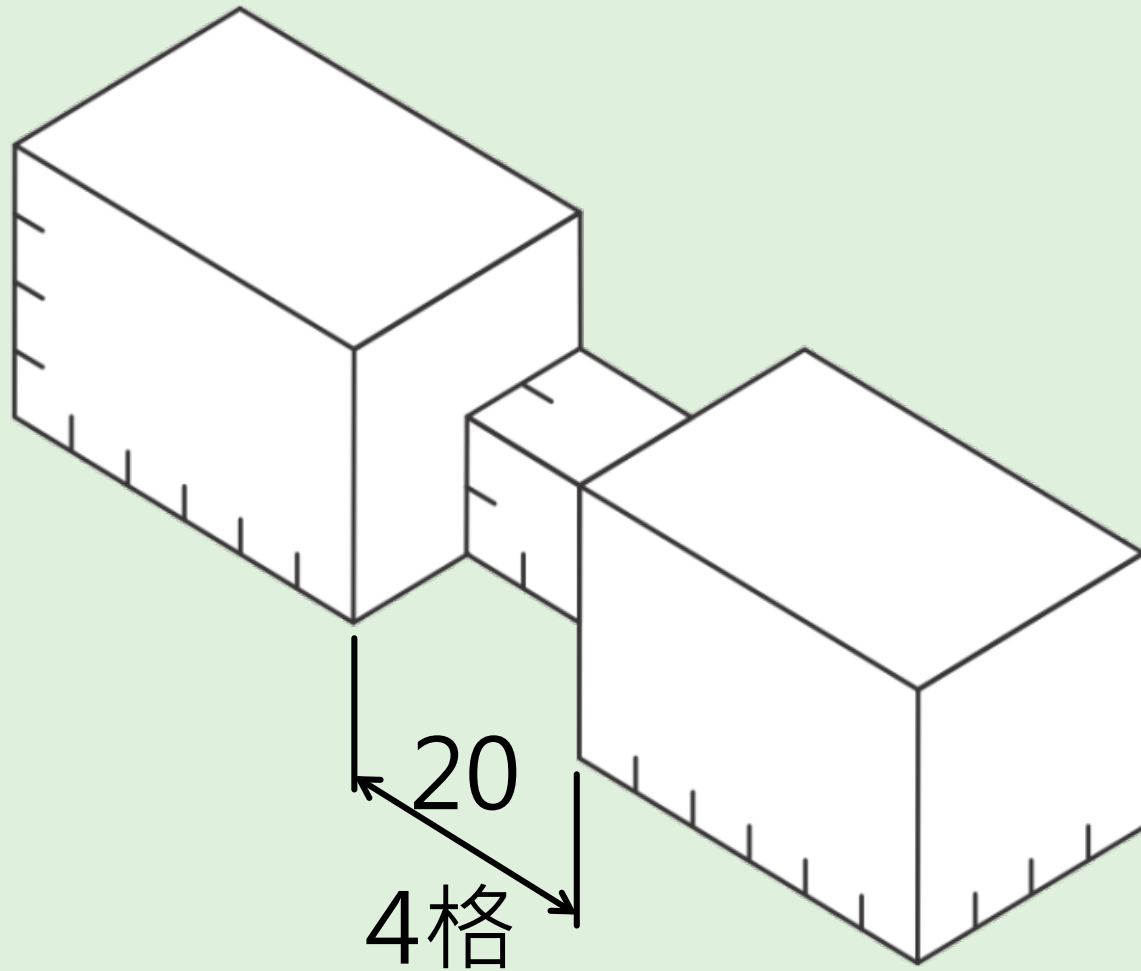

- 魯班鎖組件一：等角圖

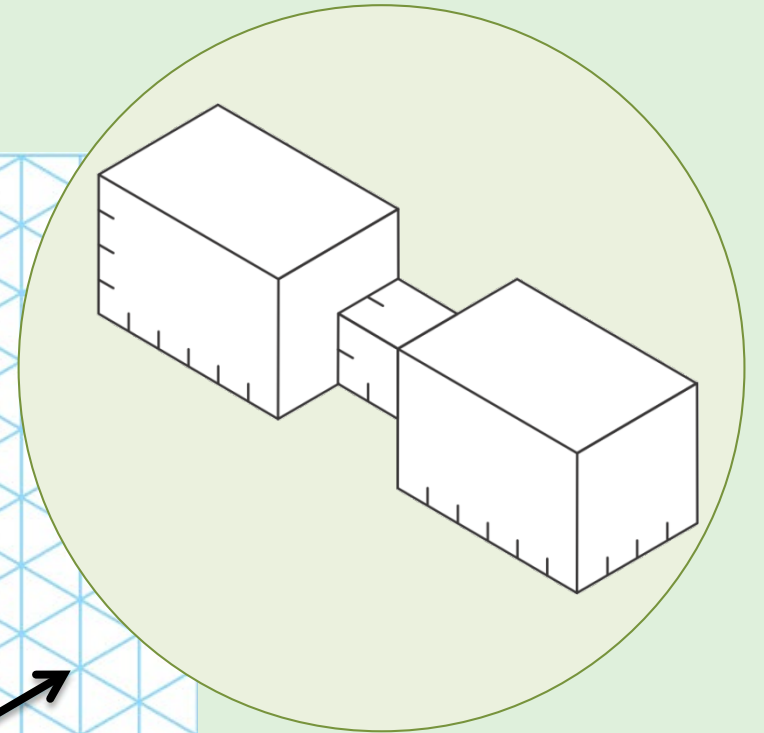
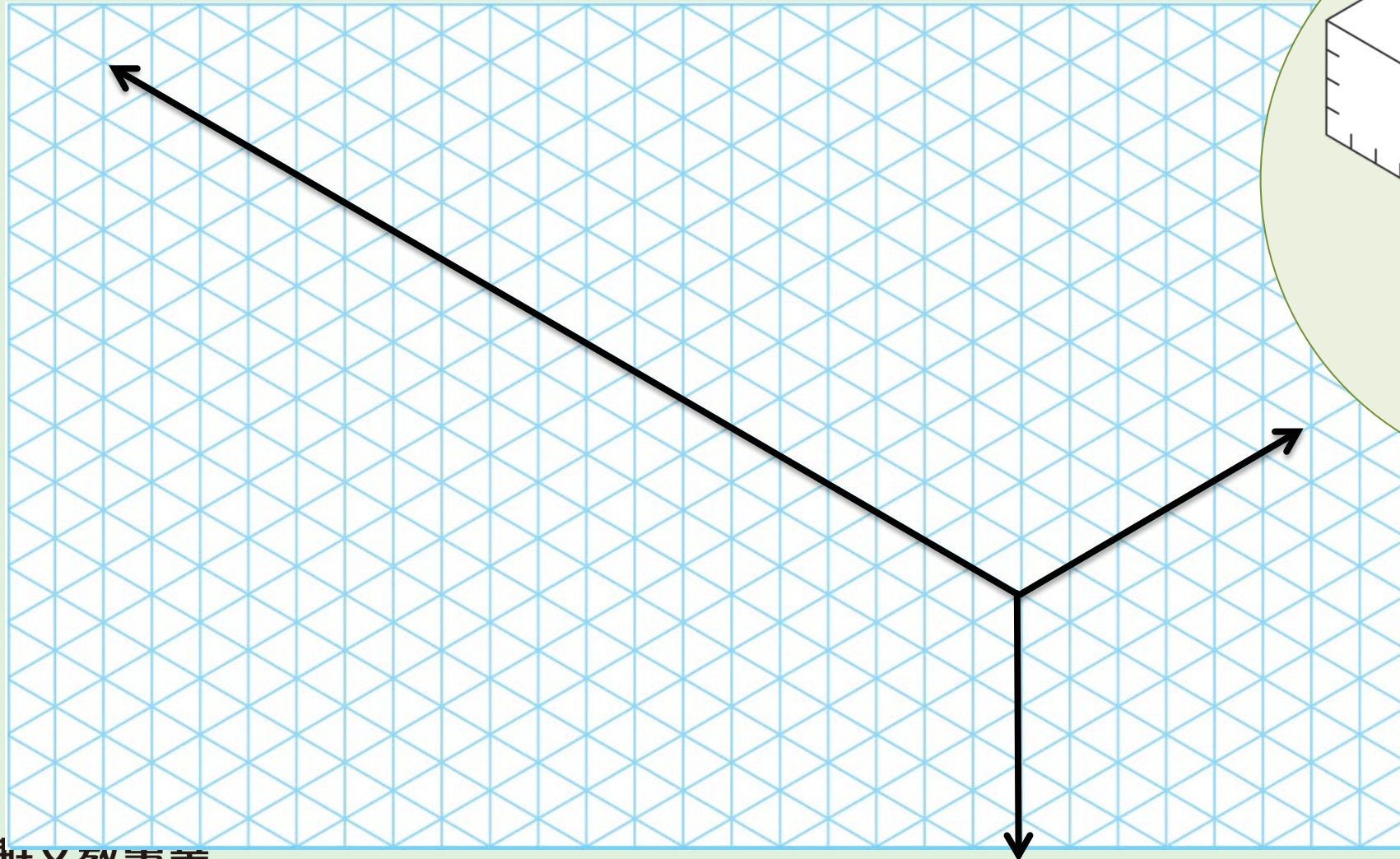

- 魯班鎖組件一：等角圖

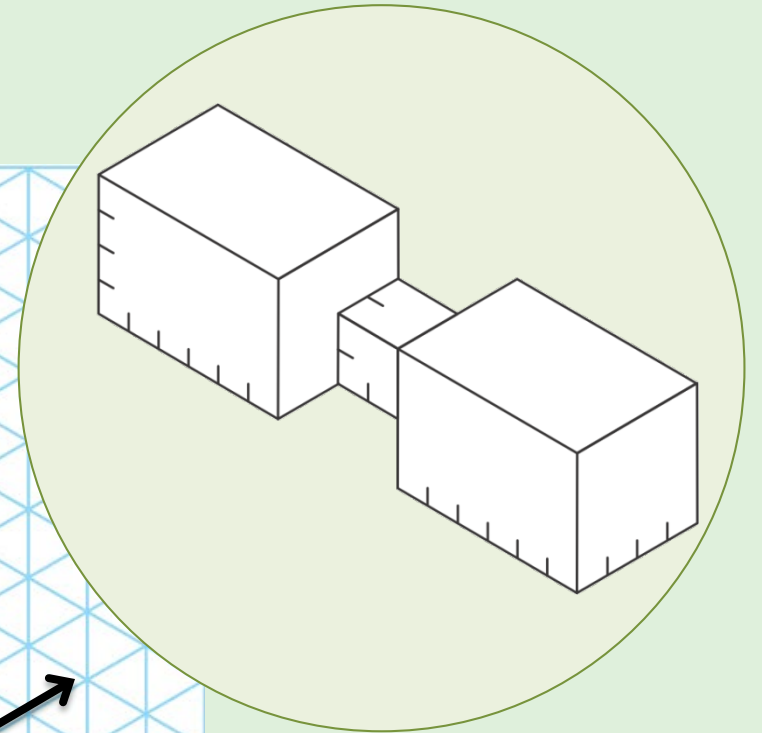
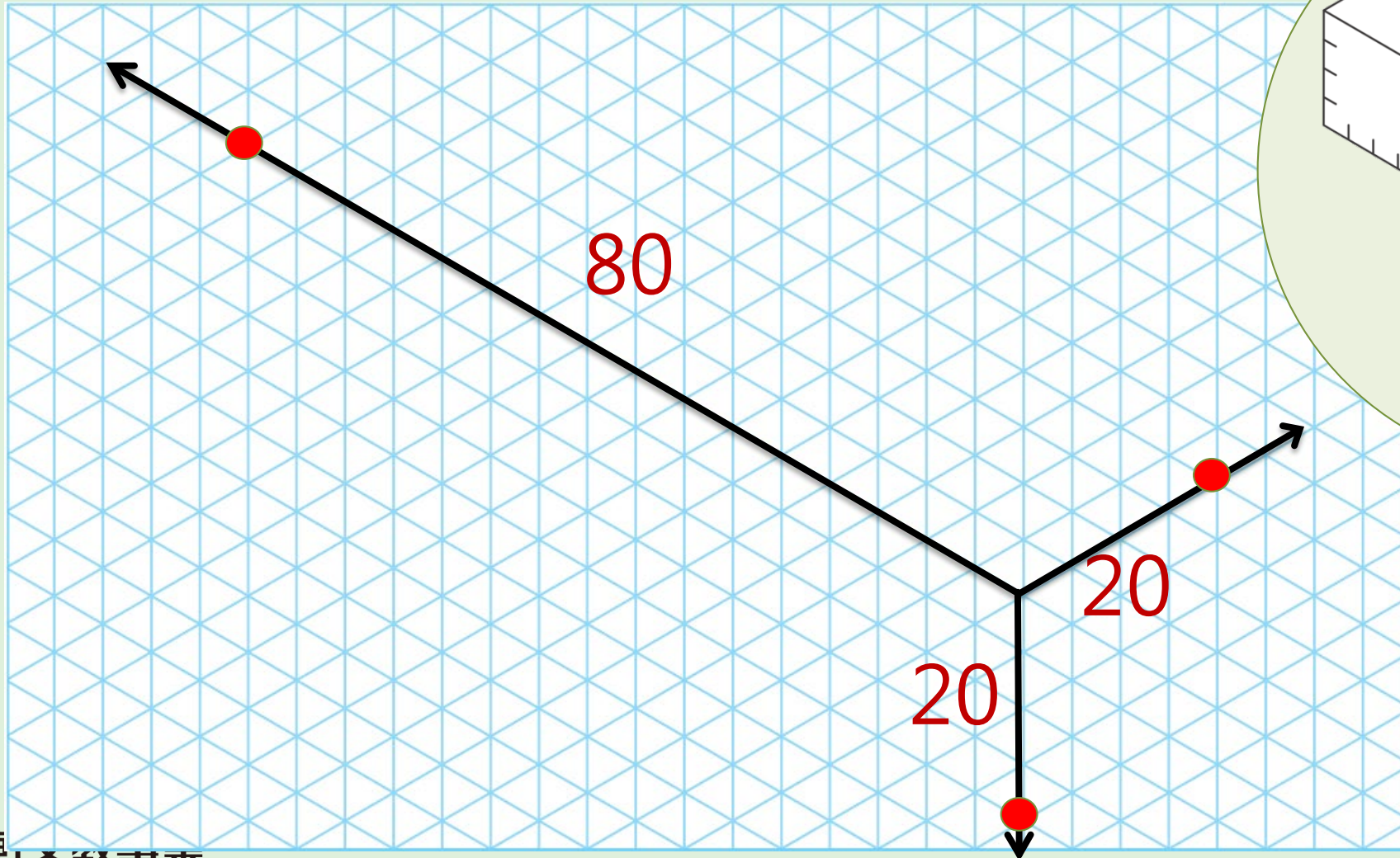

魯班鎖組件一：等角圖

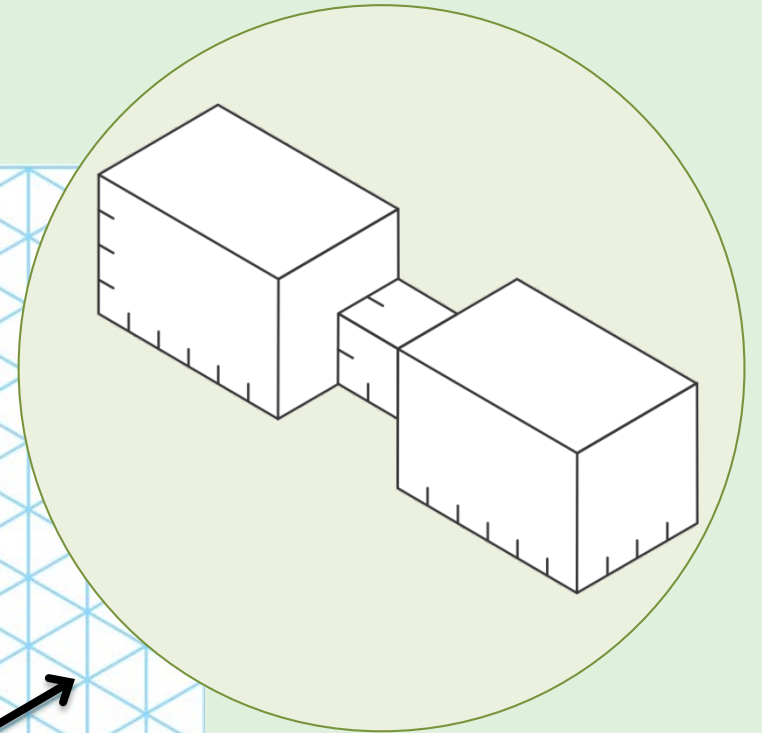
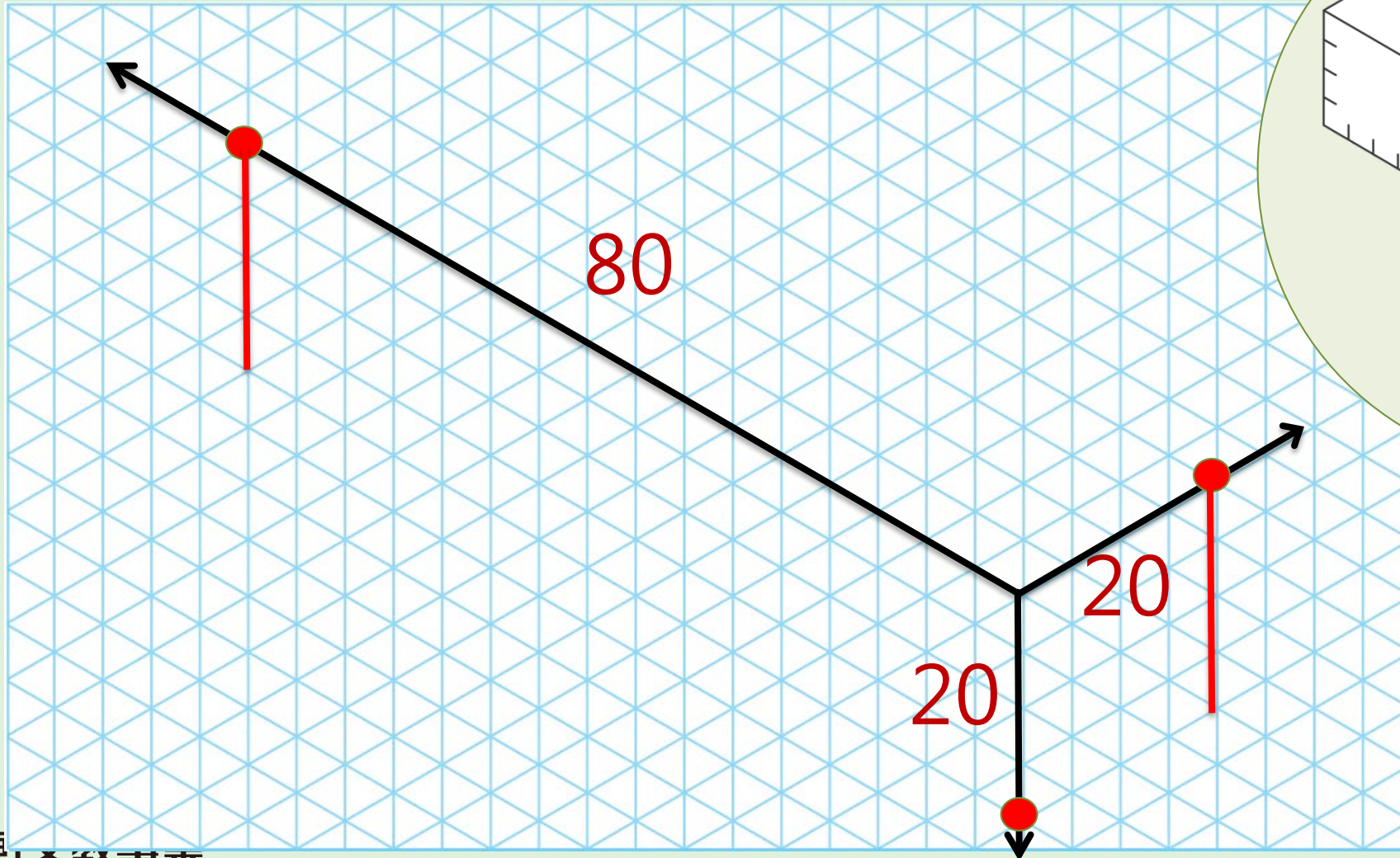

魯班鎖組件一：等角圖

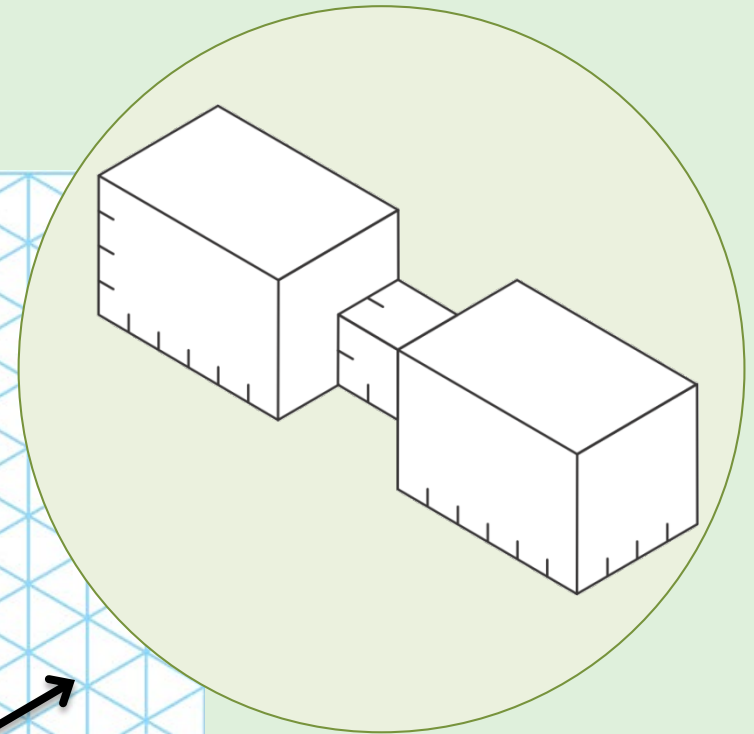
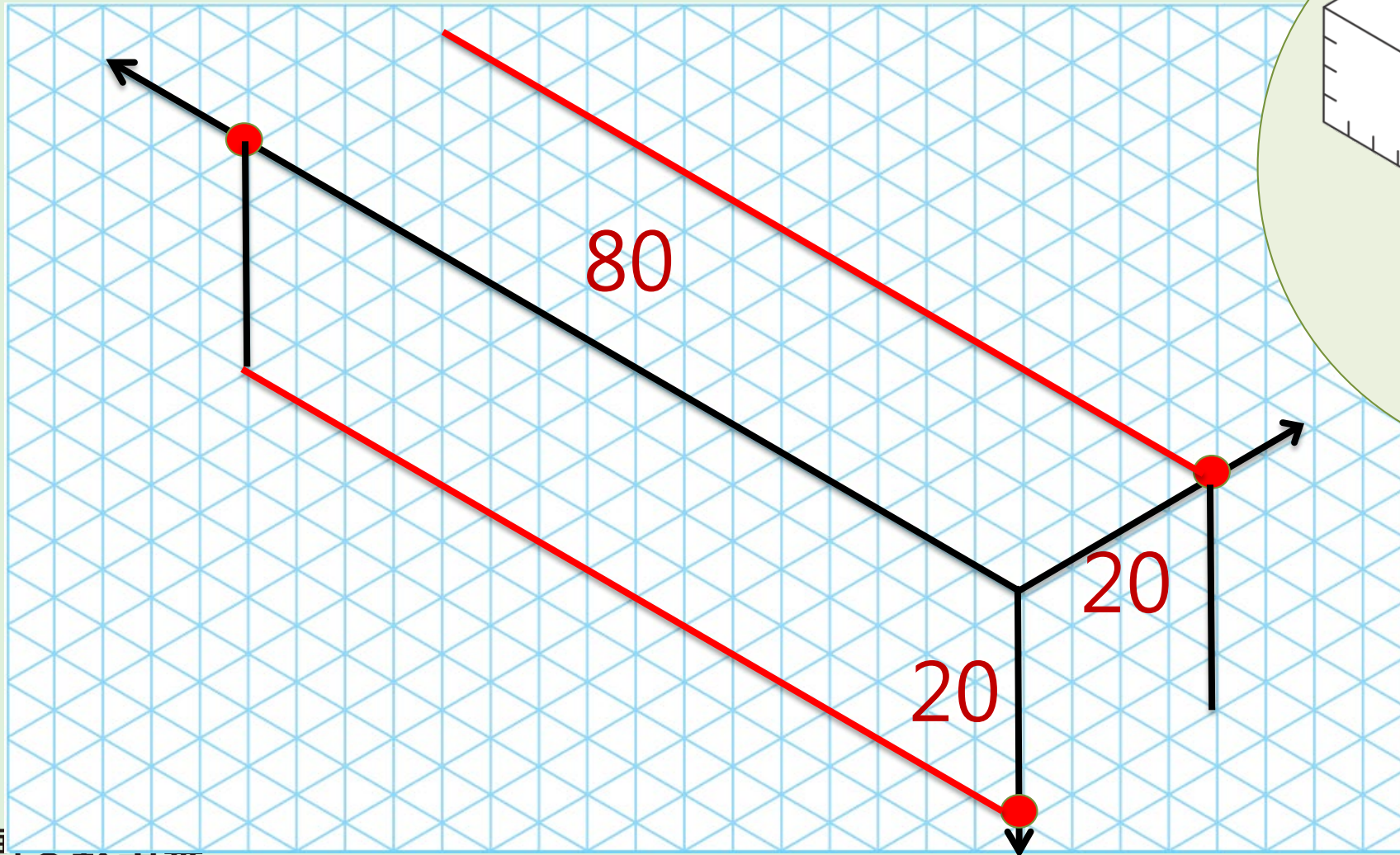

魯班鎖組件一：等角圖

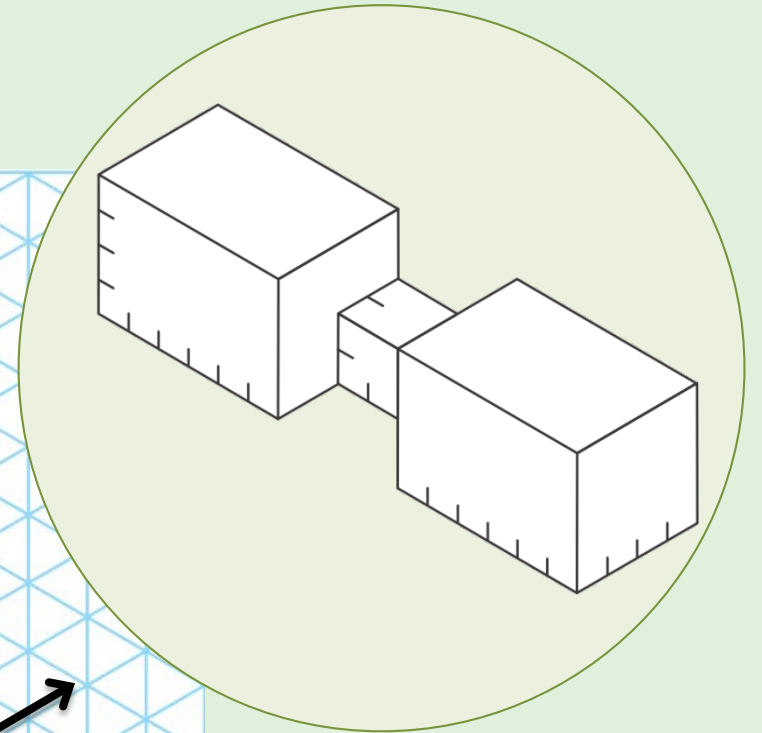
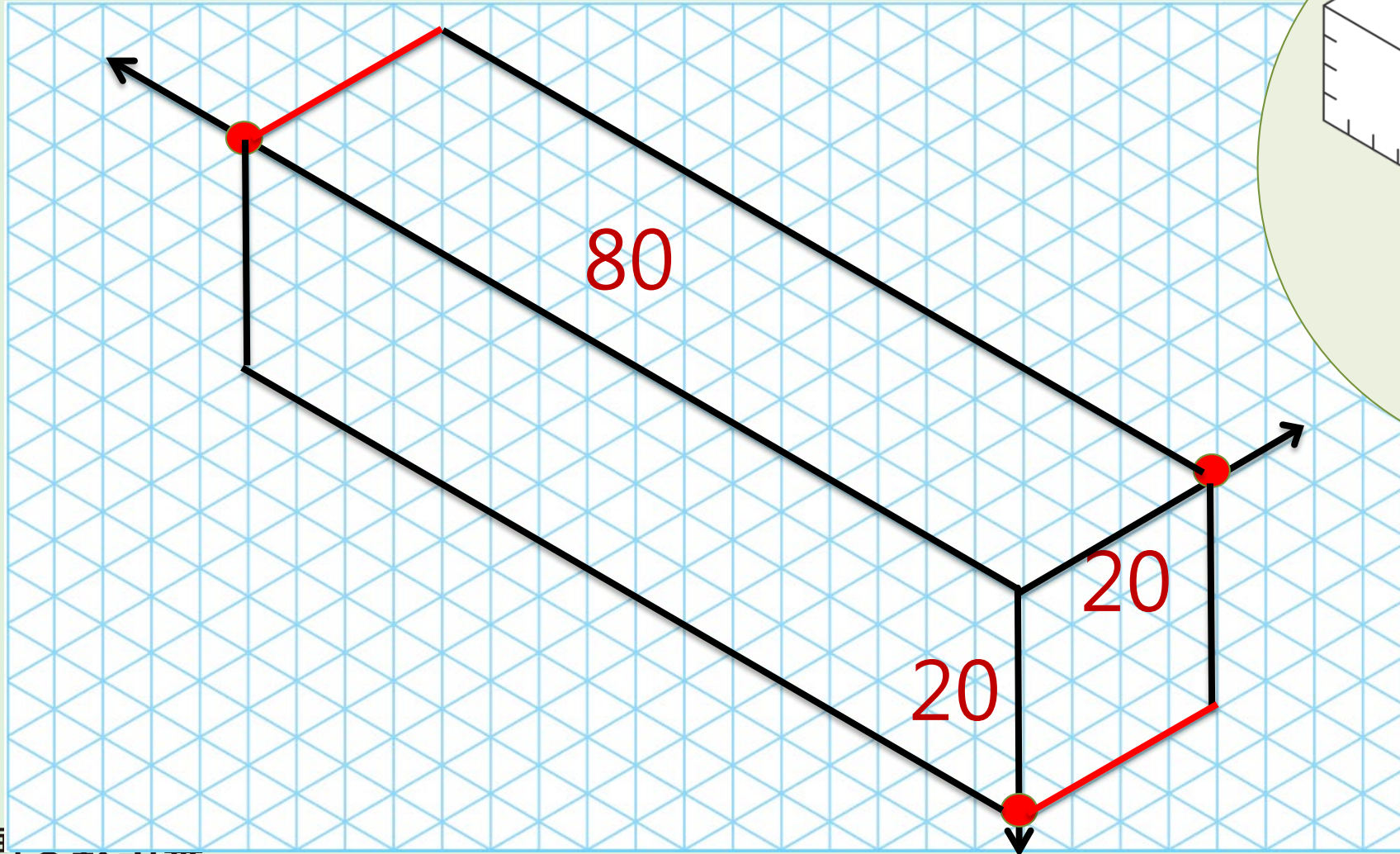

魯班鎖組件一：等角圖

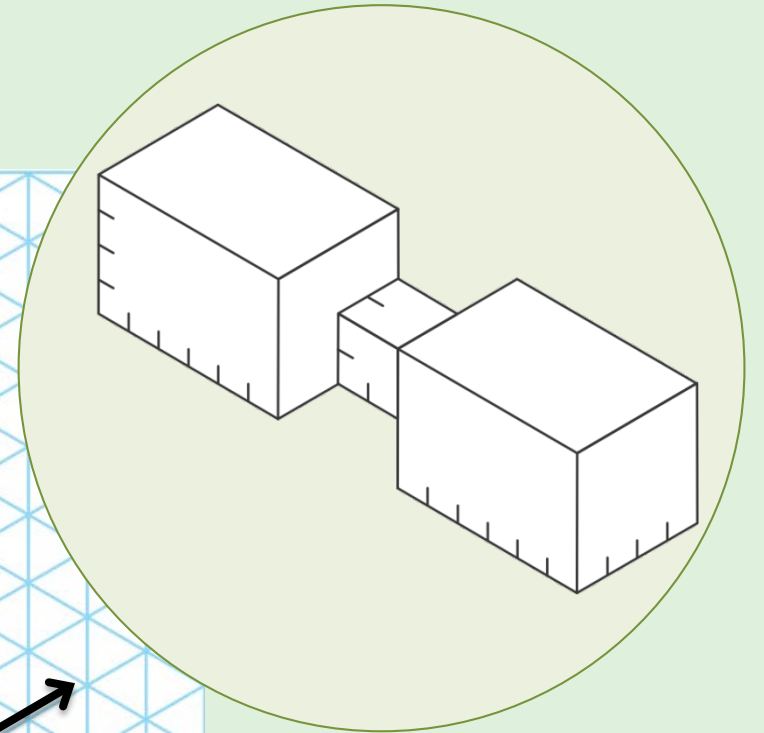
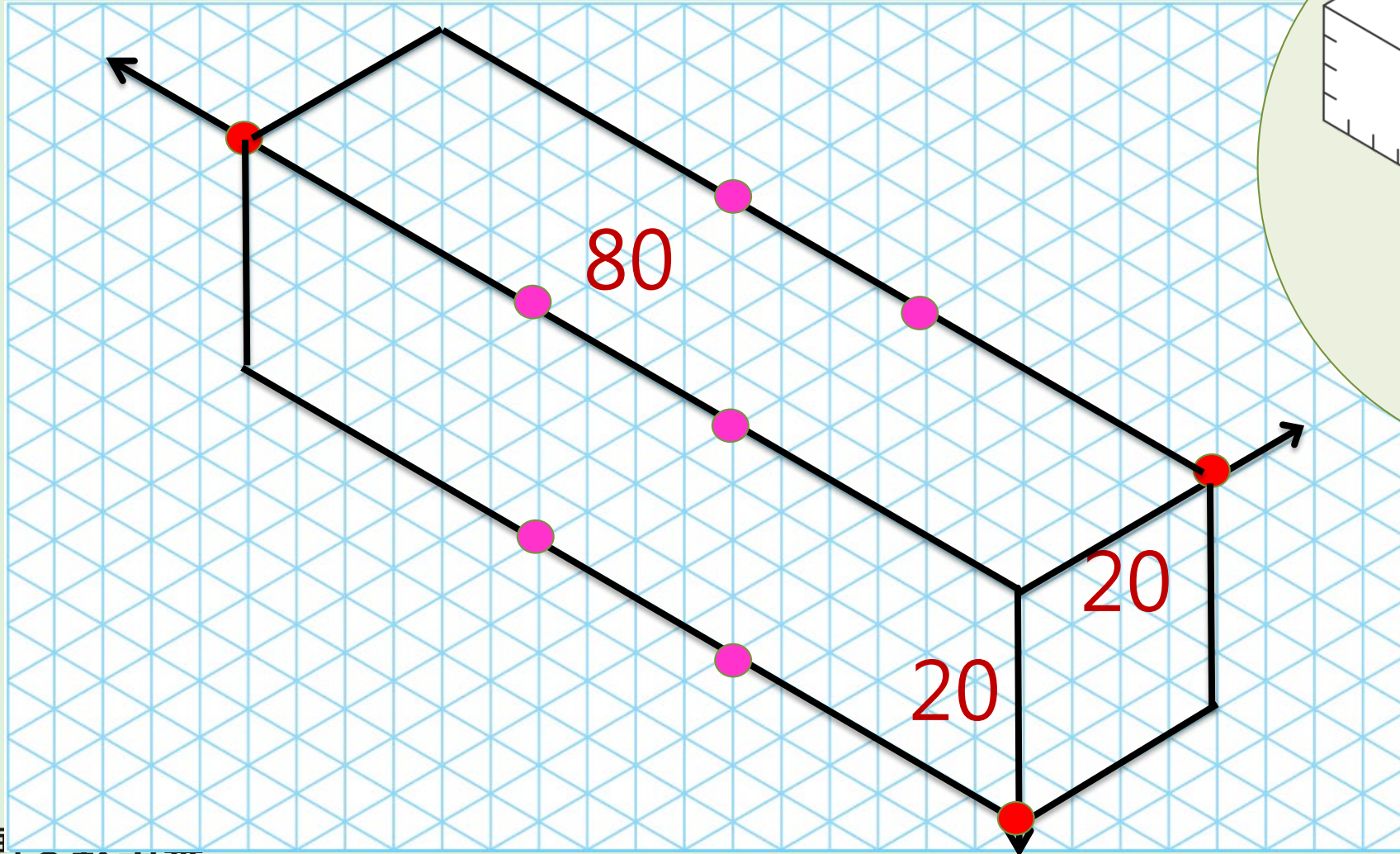

魯班鎖組件一：等角圖

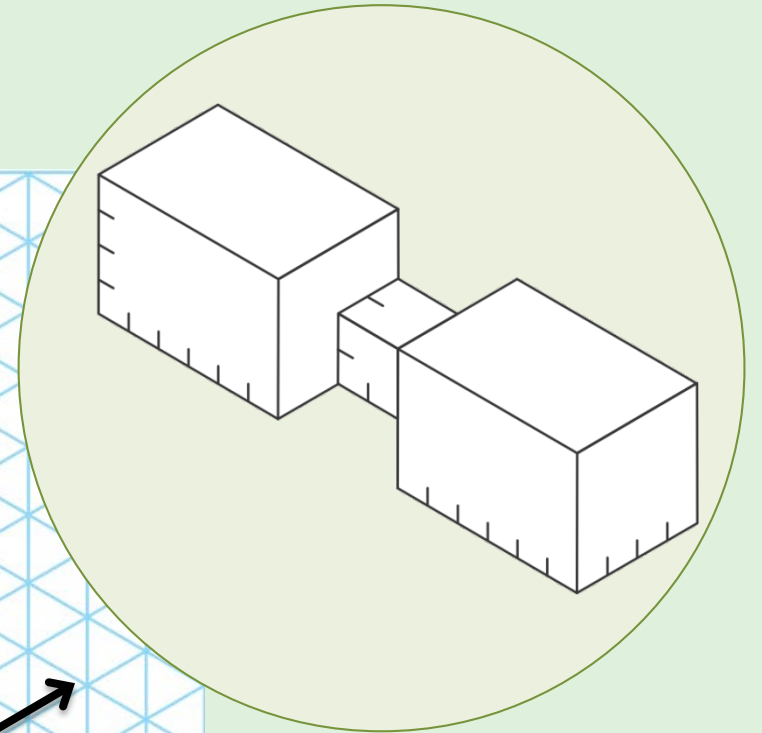
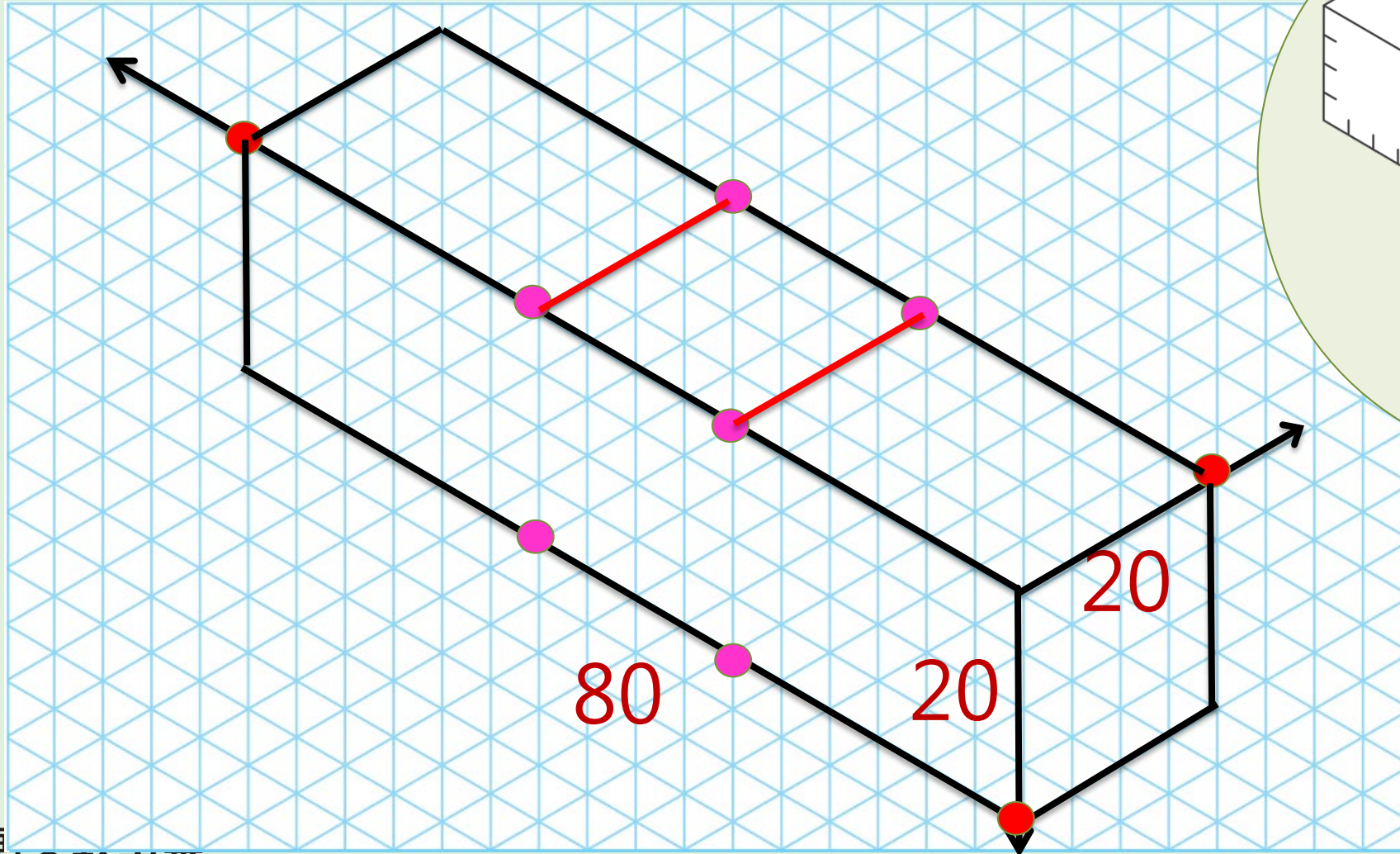

魯班鎖組件一：等角圖

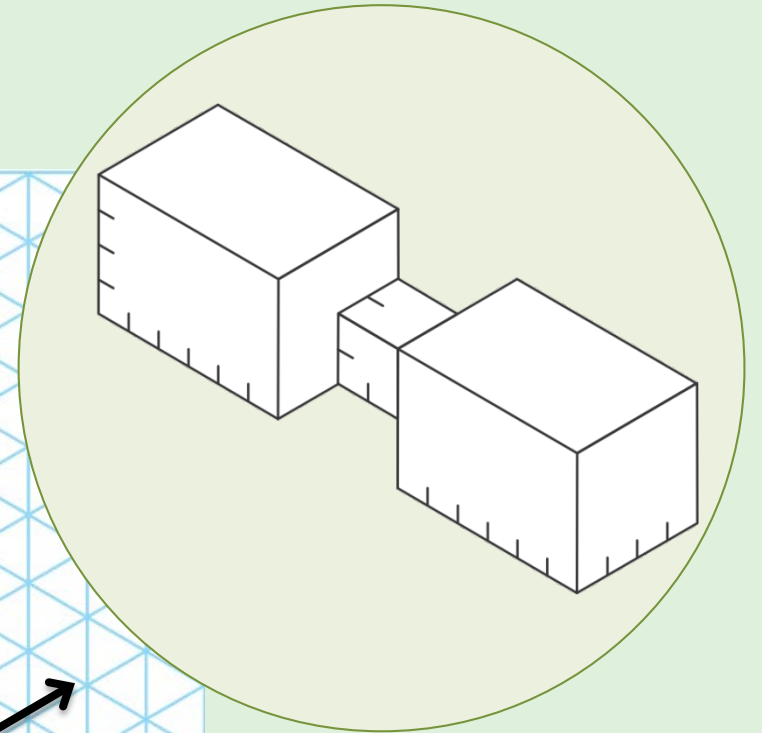
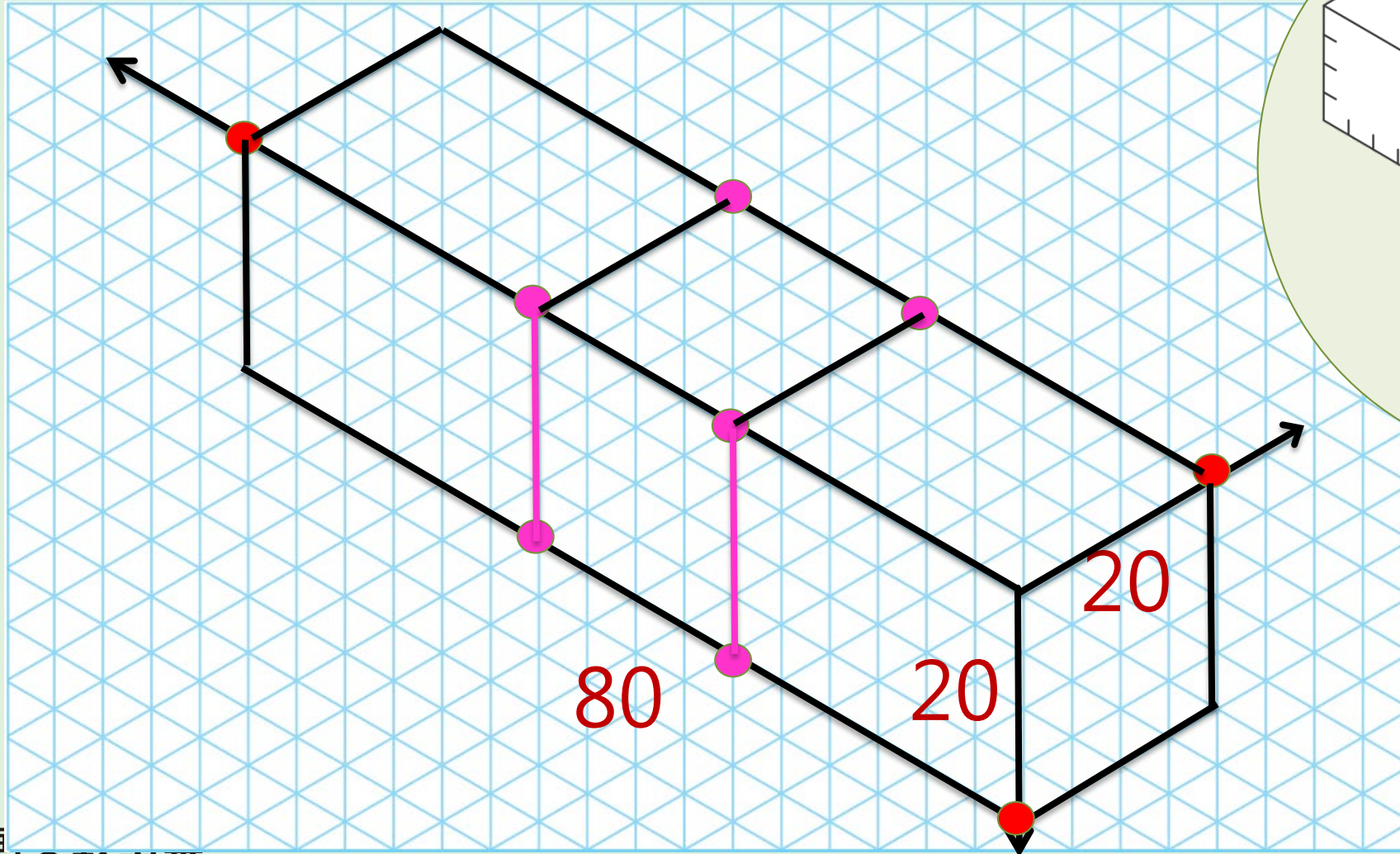

魯班鎖組件一：等角圖

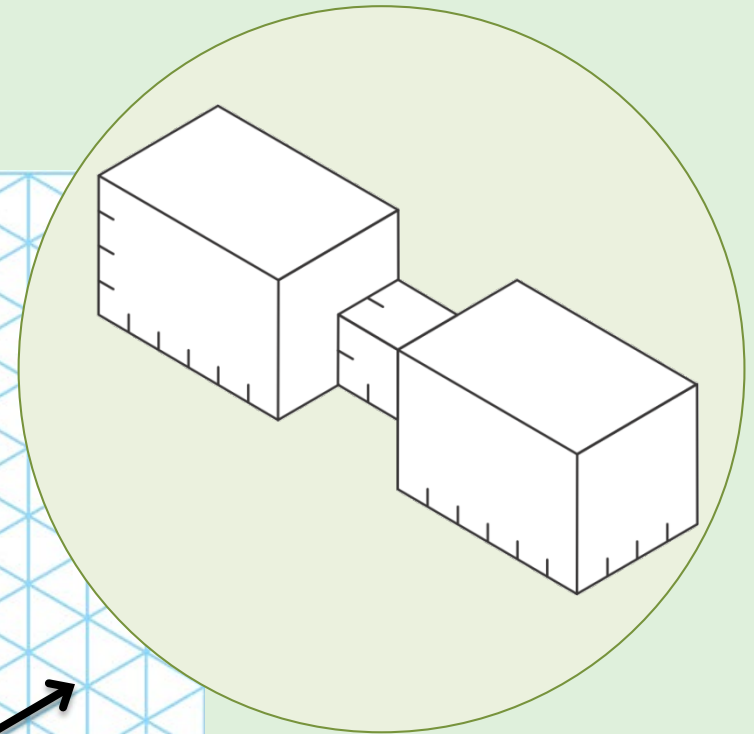
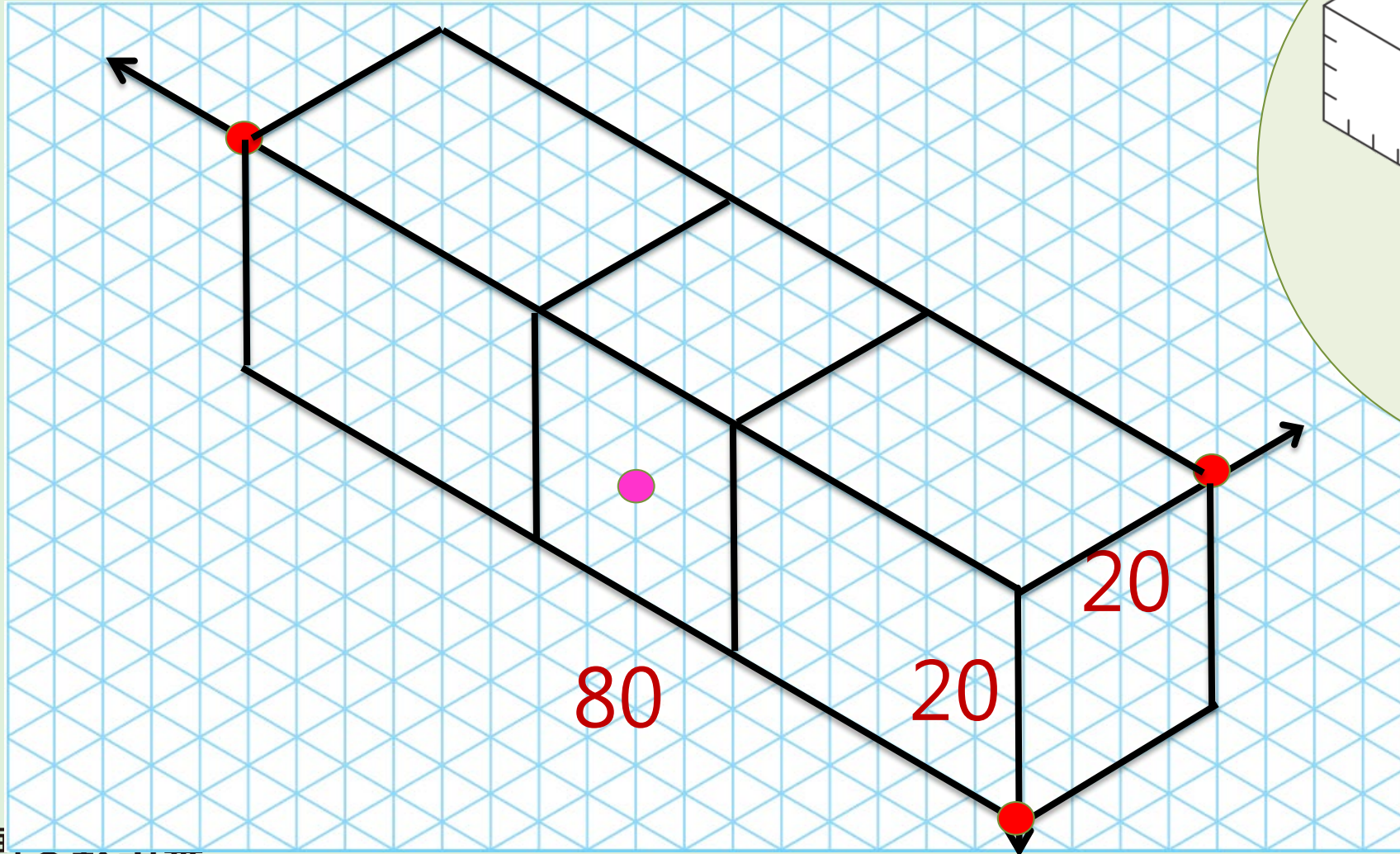

魯班鎖組件一：等角圖

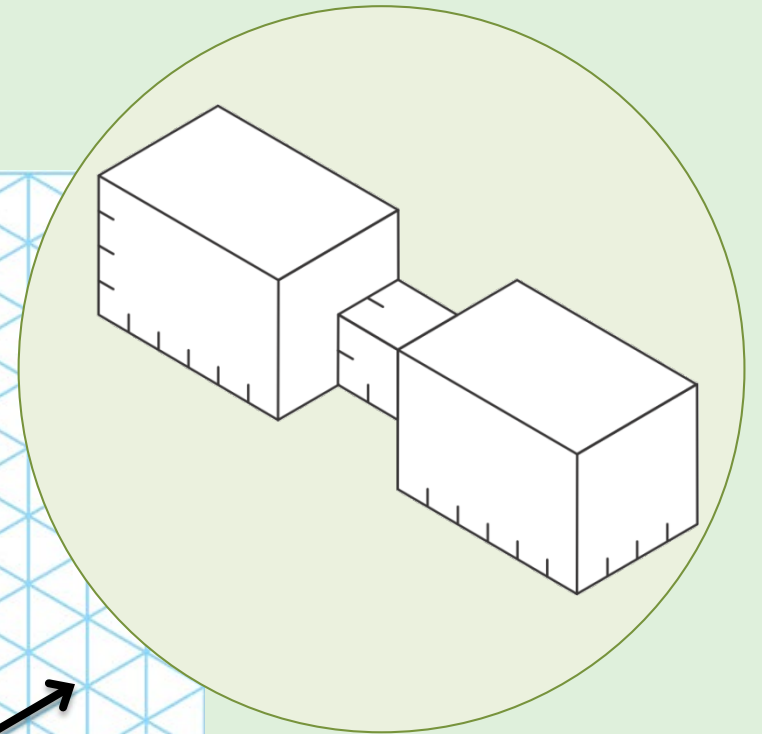
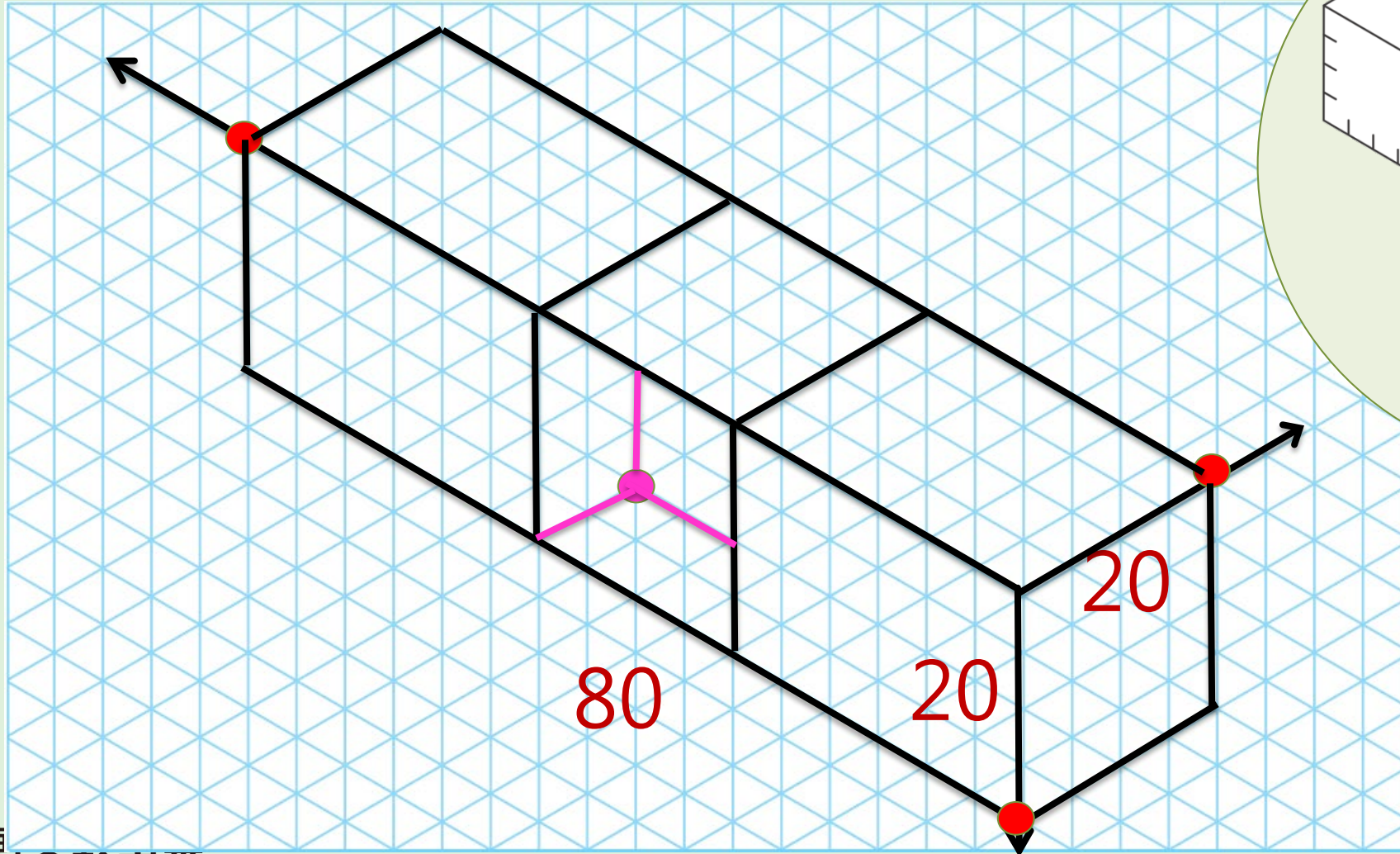

魯班鎖組件一：等角圖

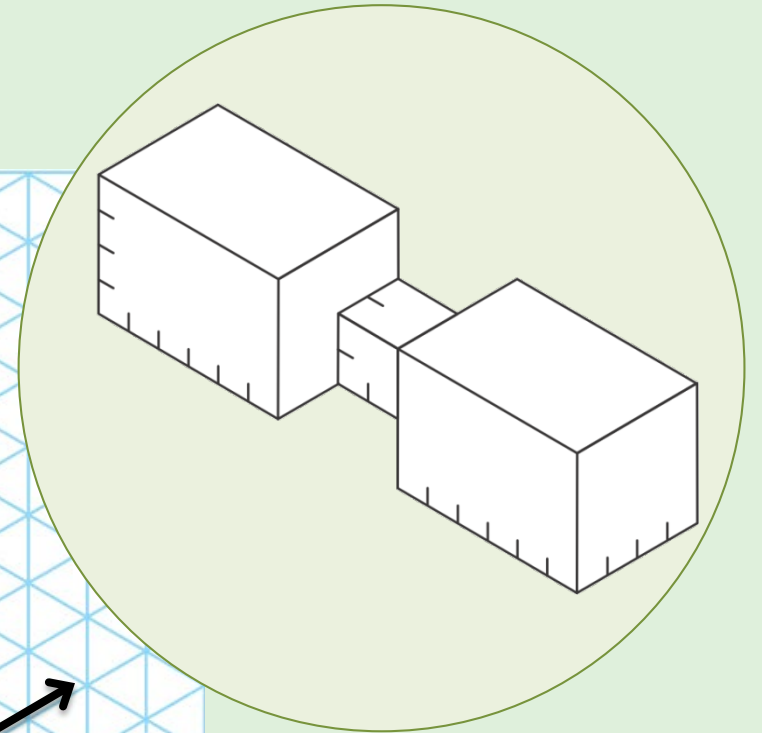
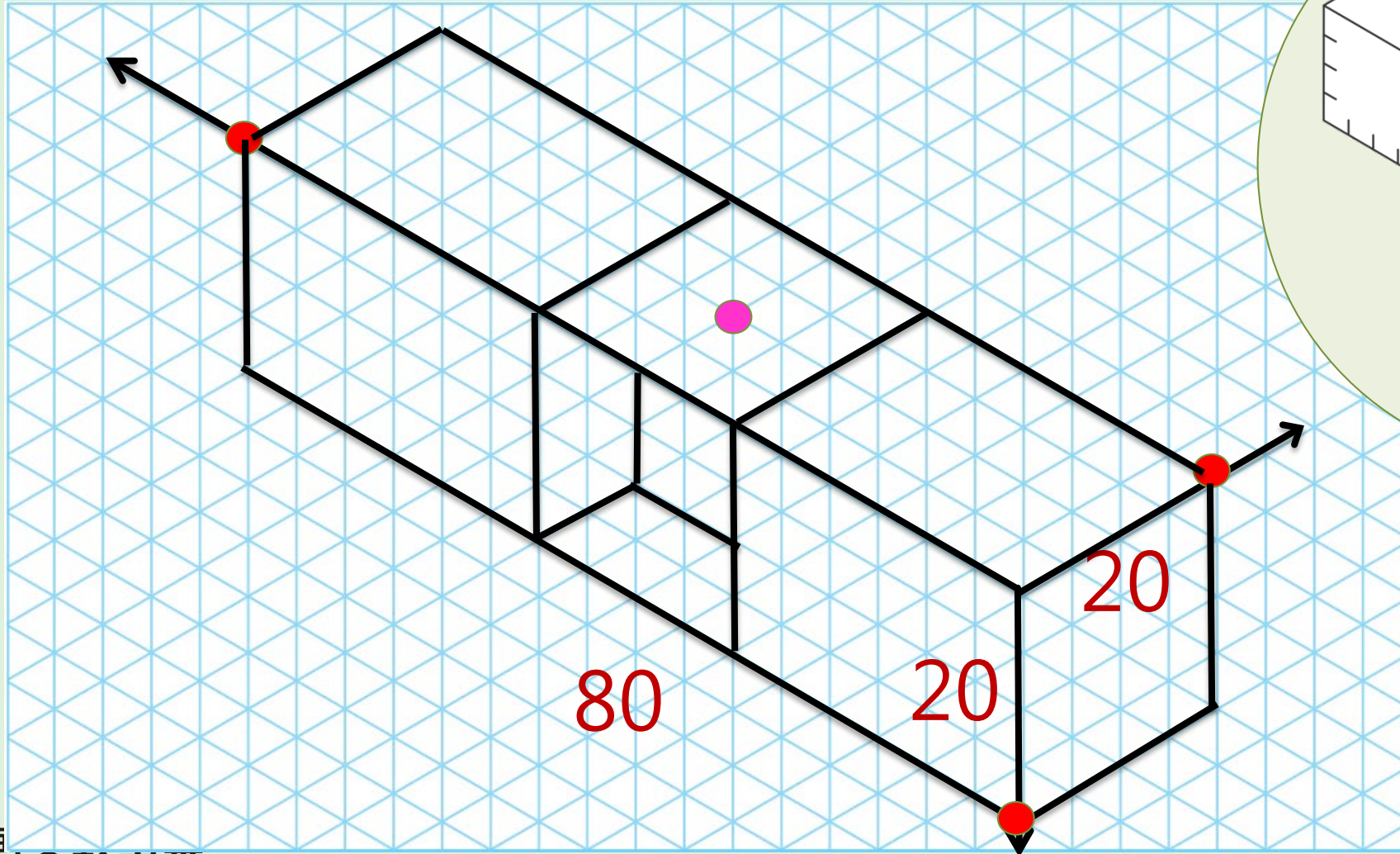

魯班鎖組件一：等角圖

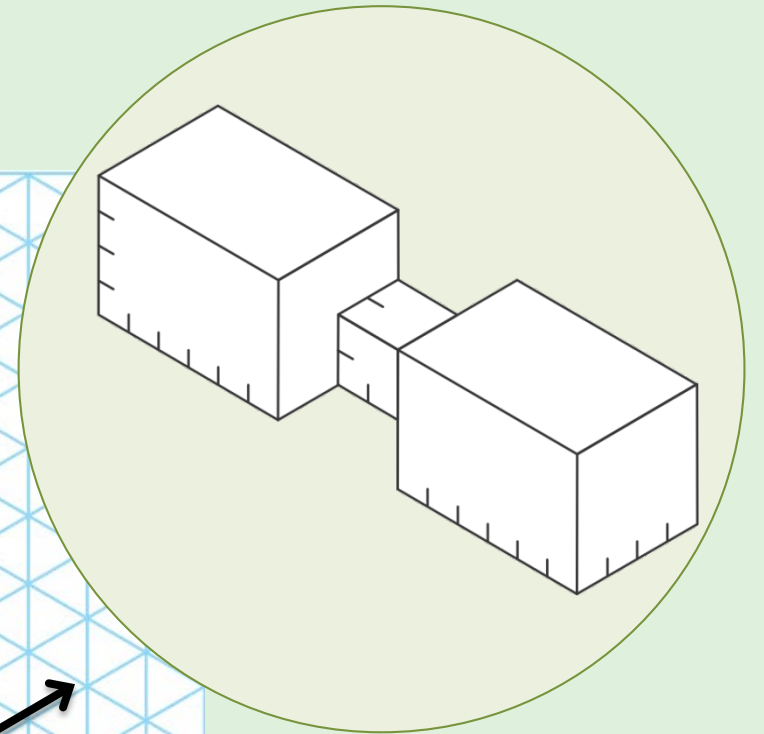
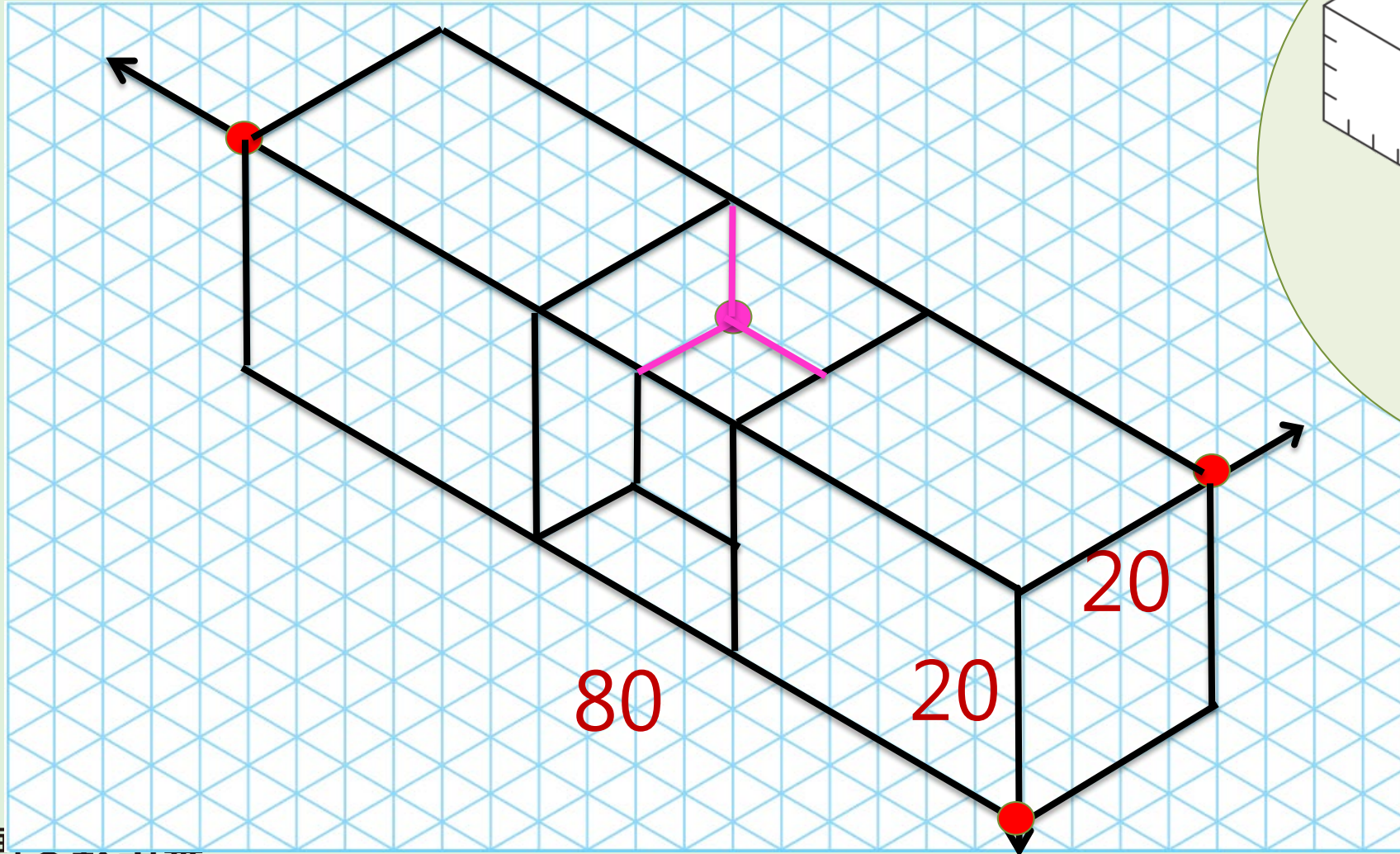

魯班鎖組件一：等角圖

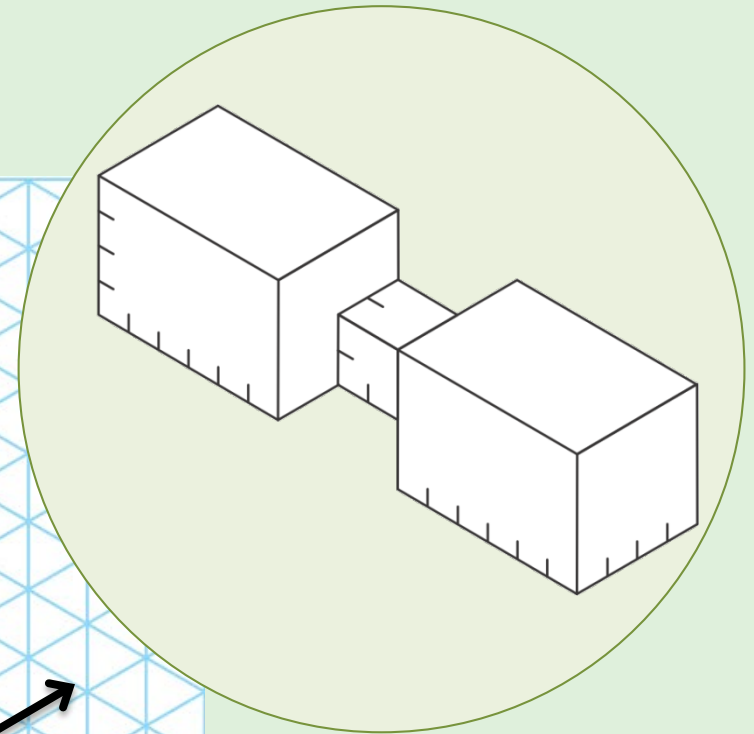
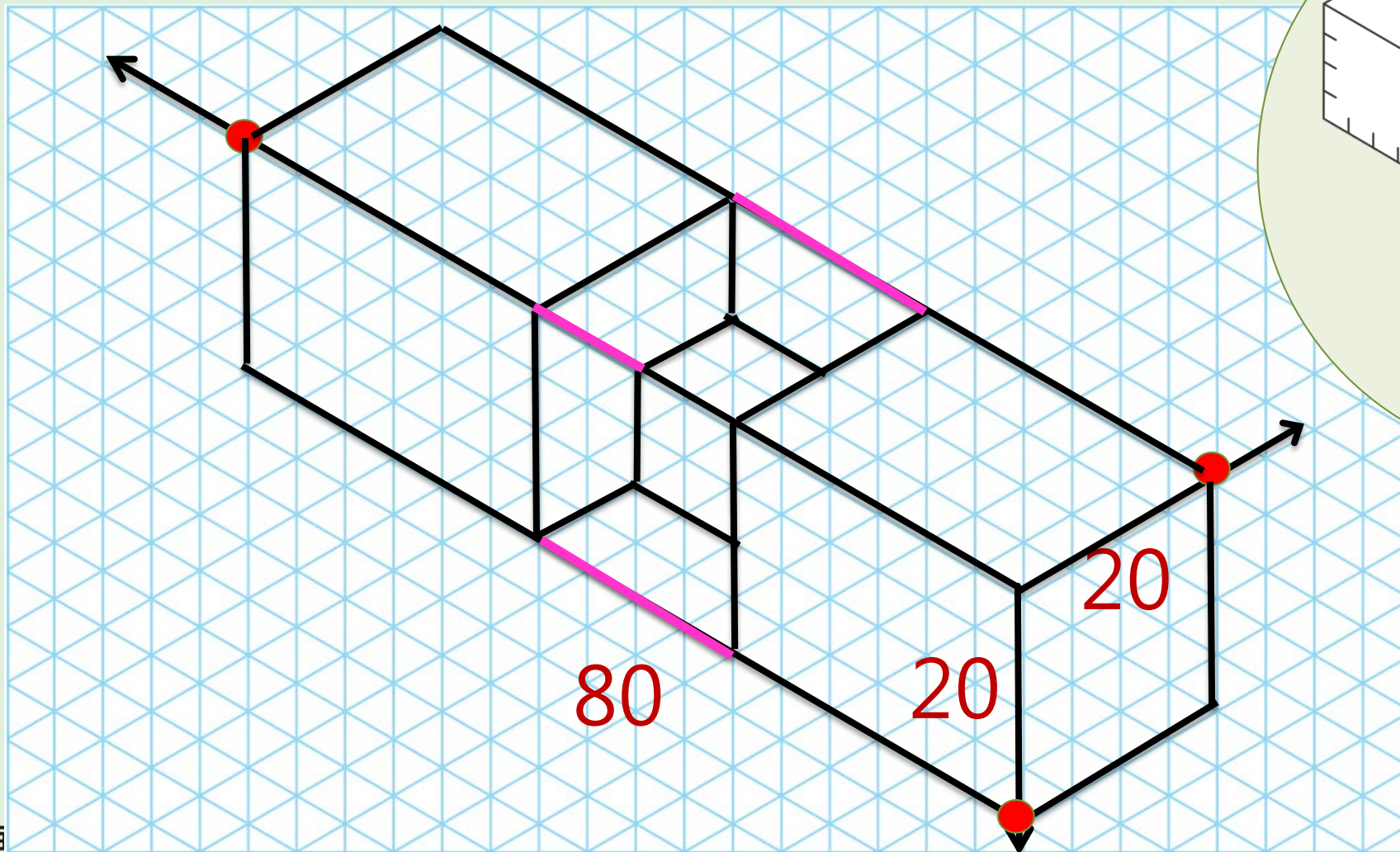

魯班鎖組件一：等角圖

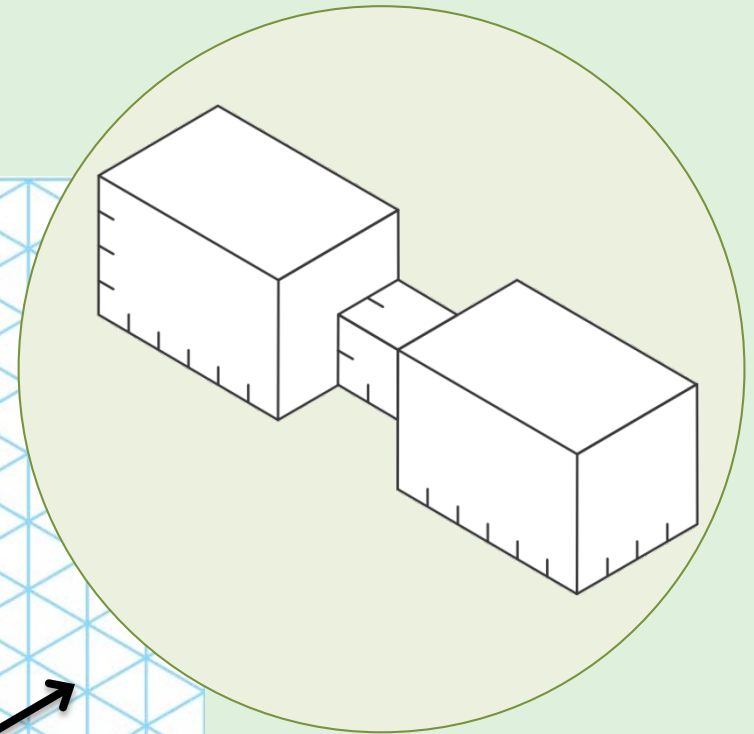
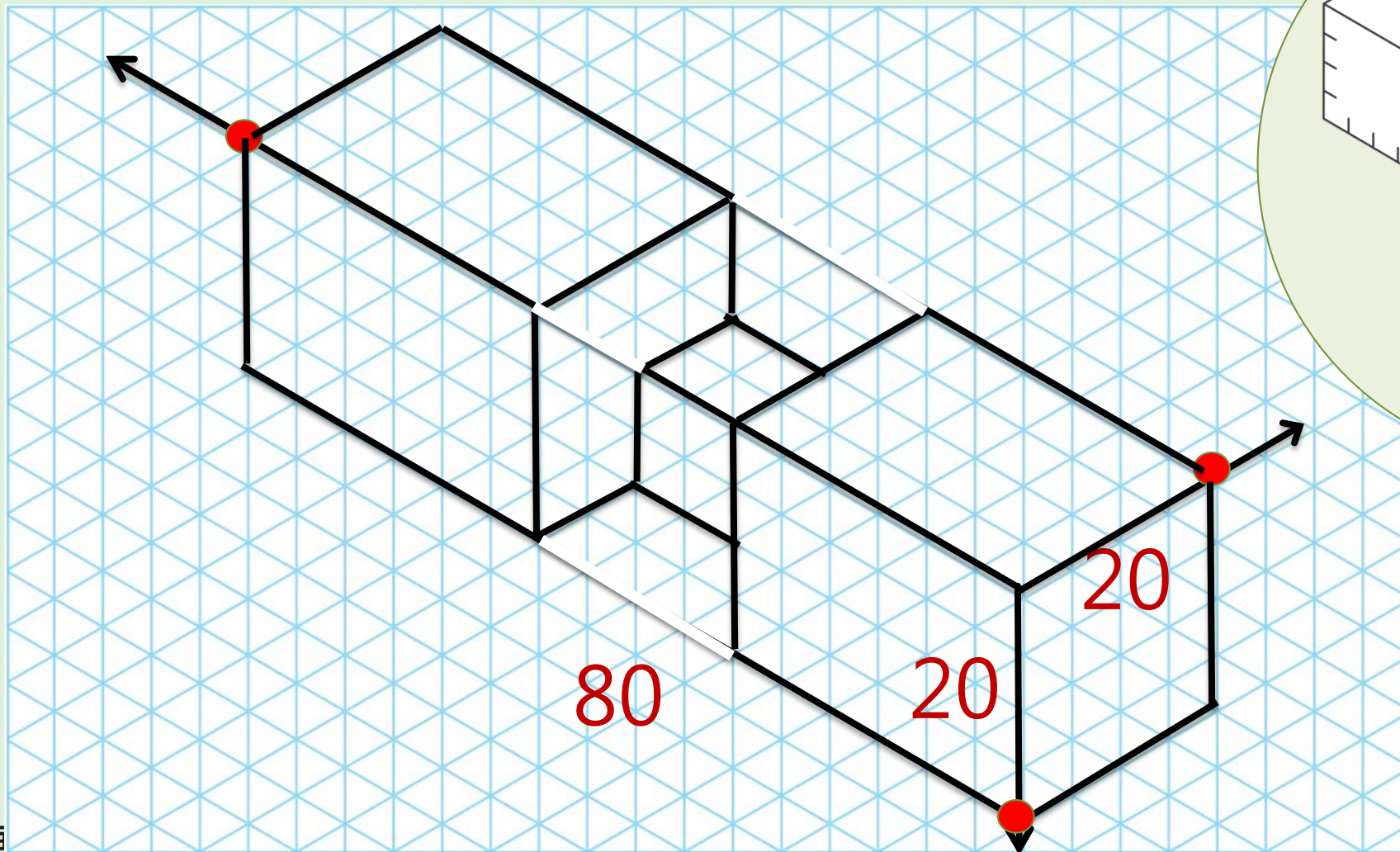

- 試試看，依據圖2-2-21繪製等角圖與等斜圖。

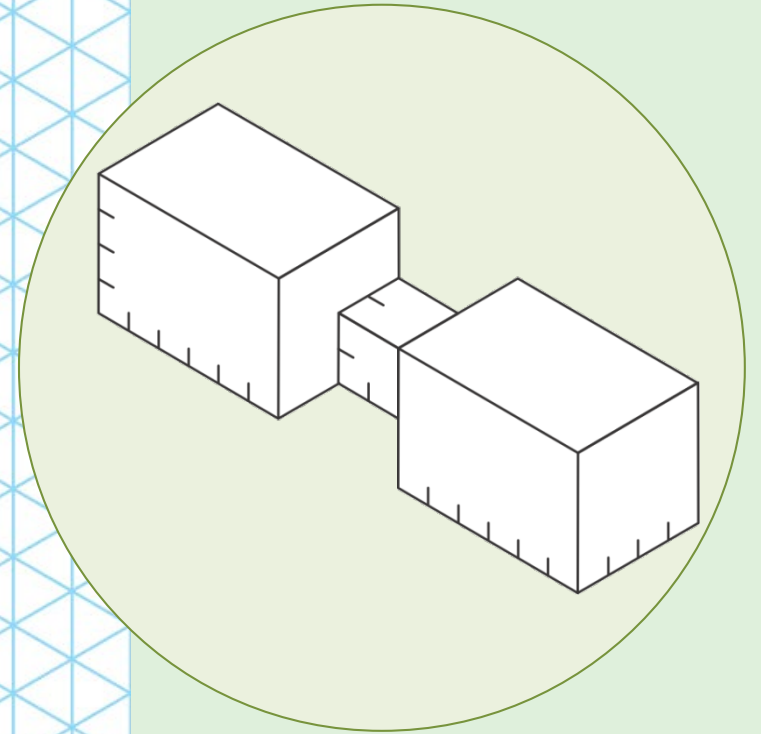
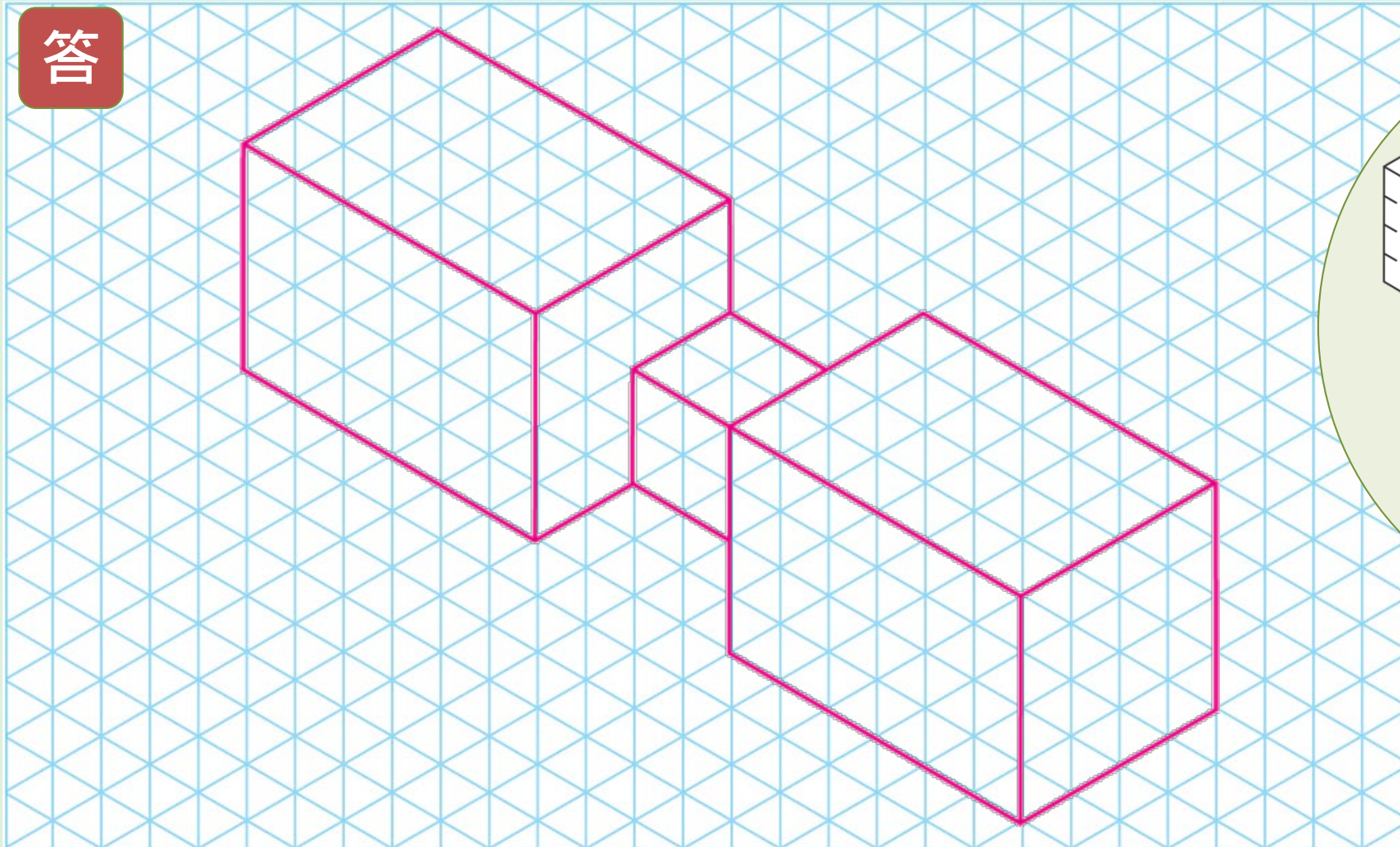

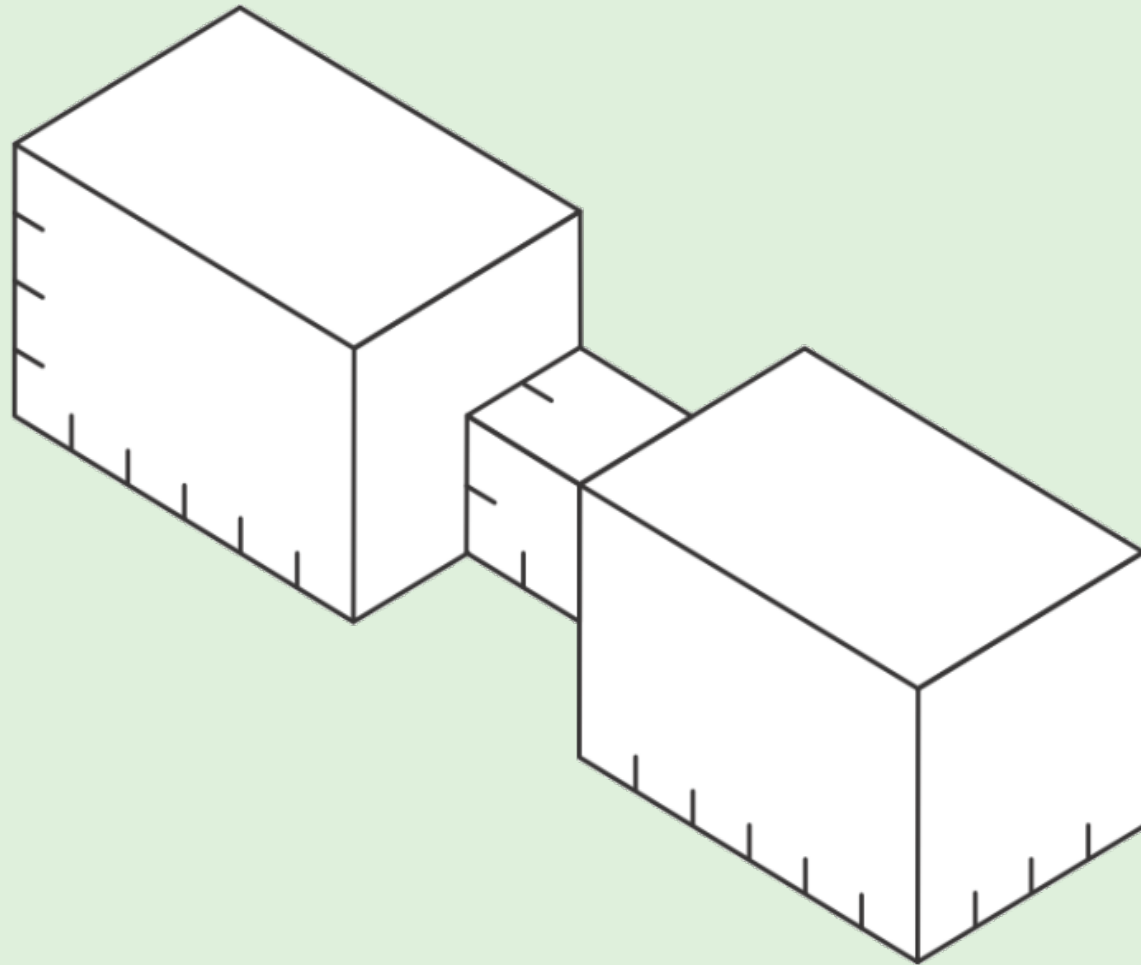

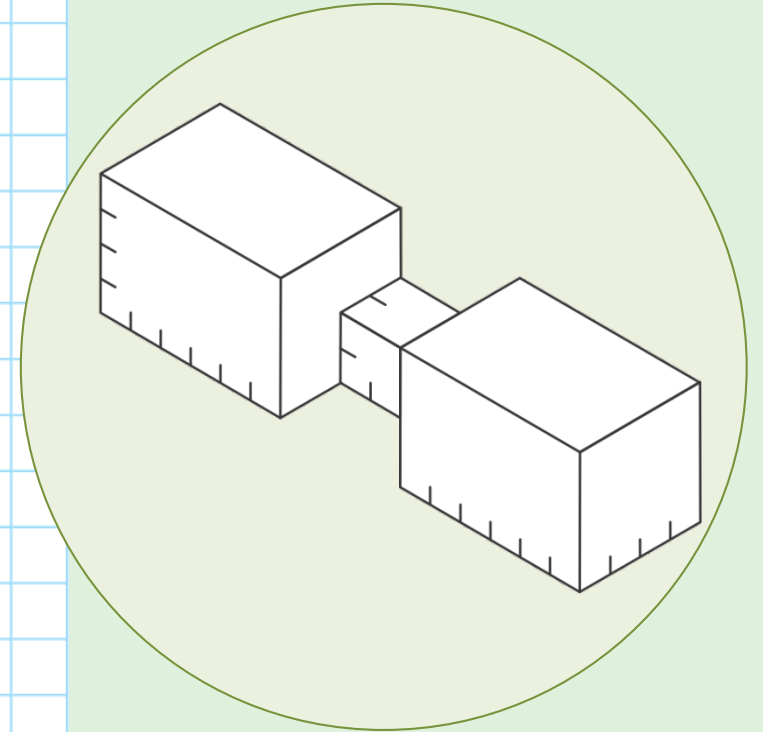
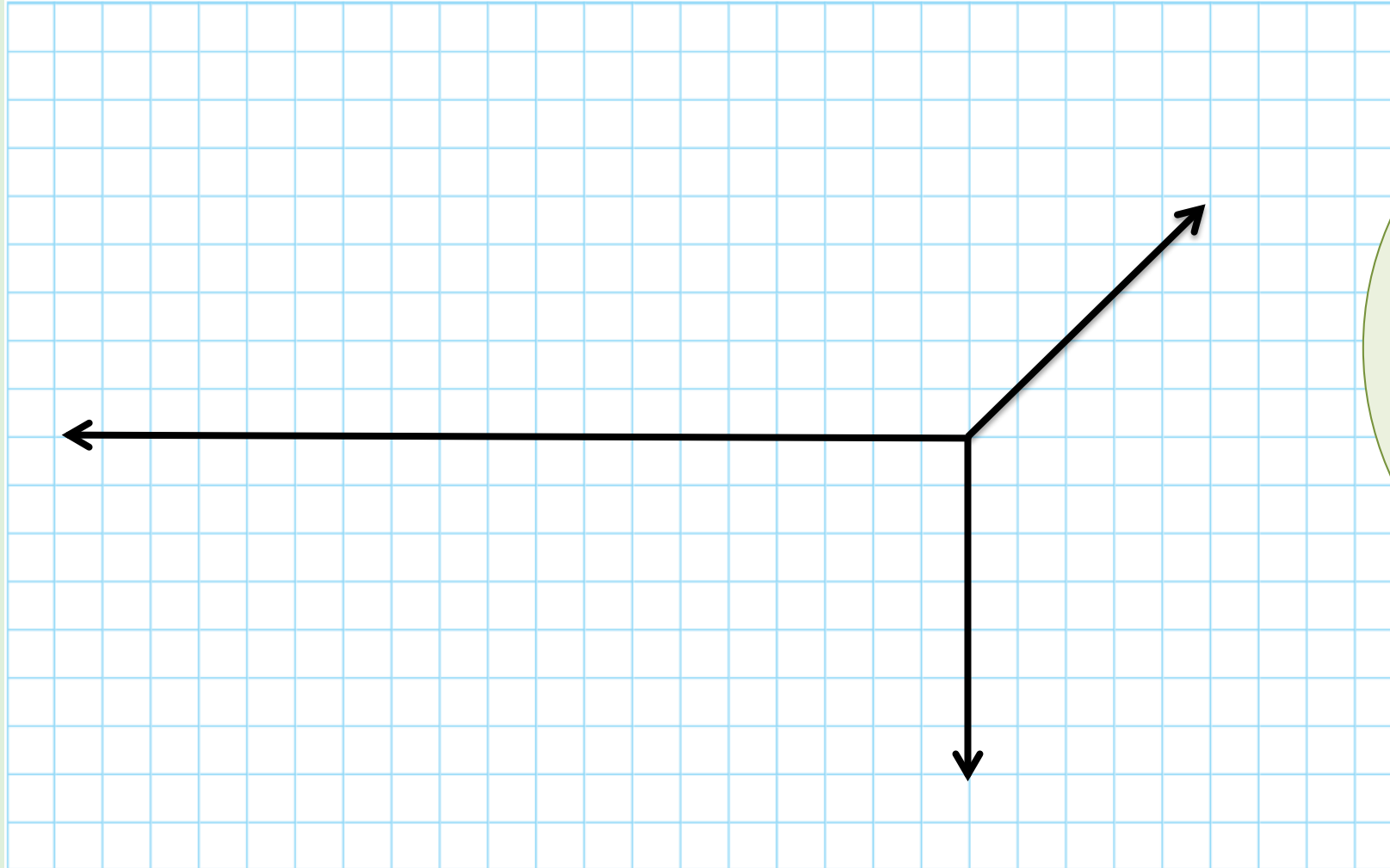

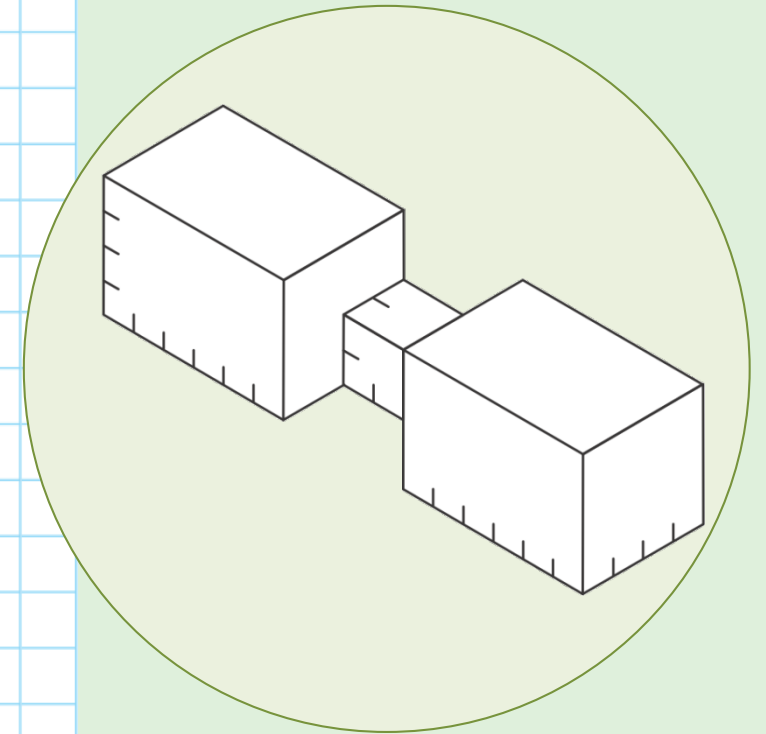
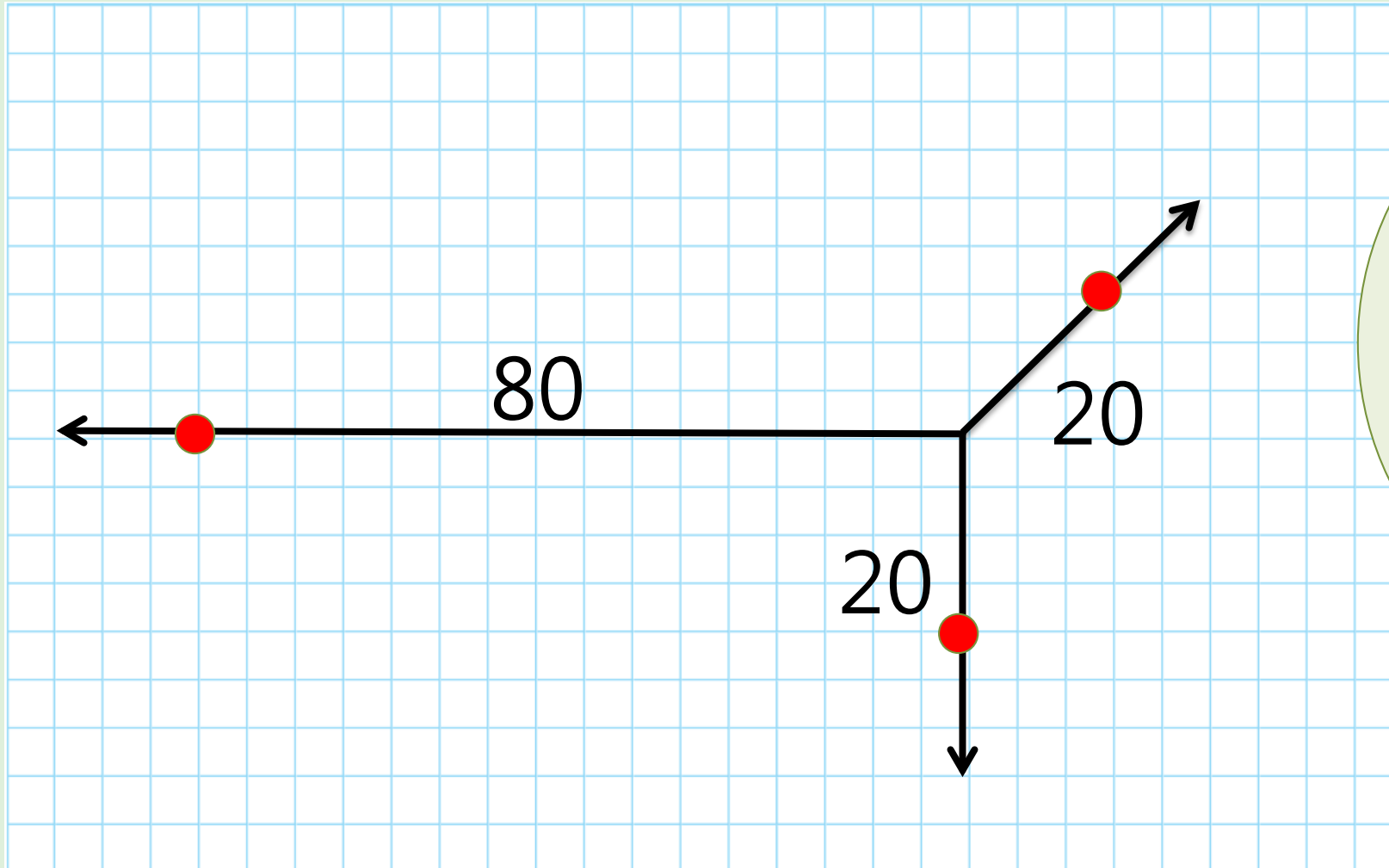

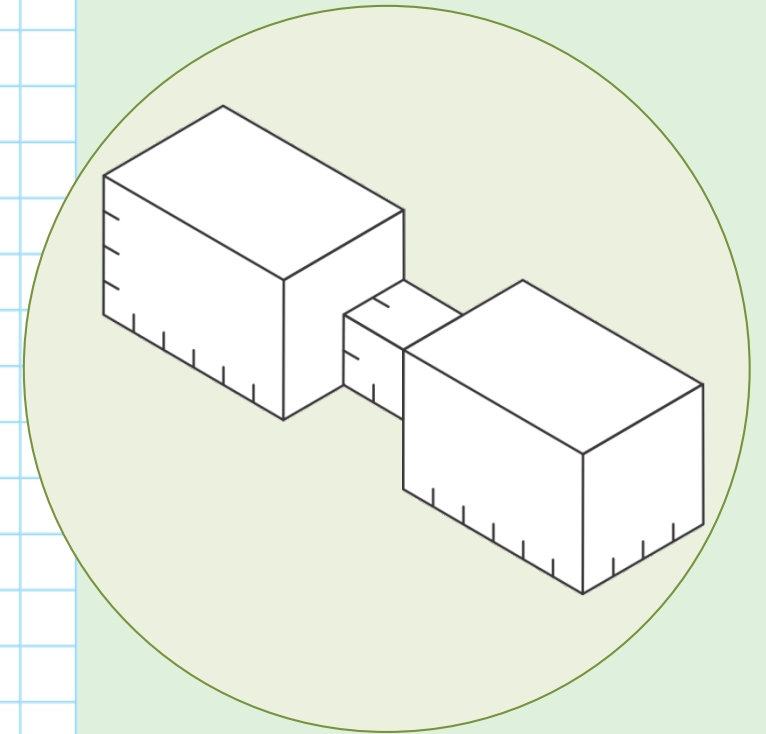
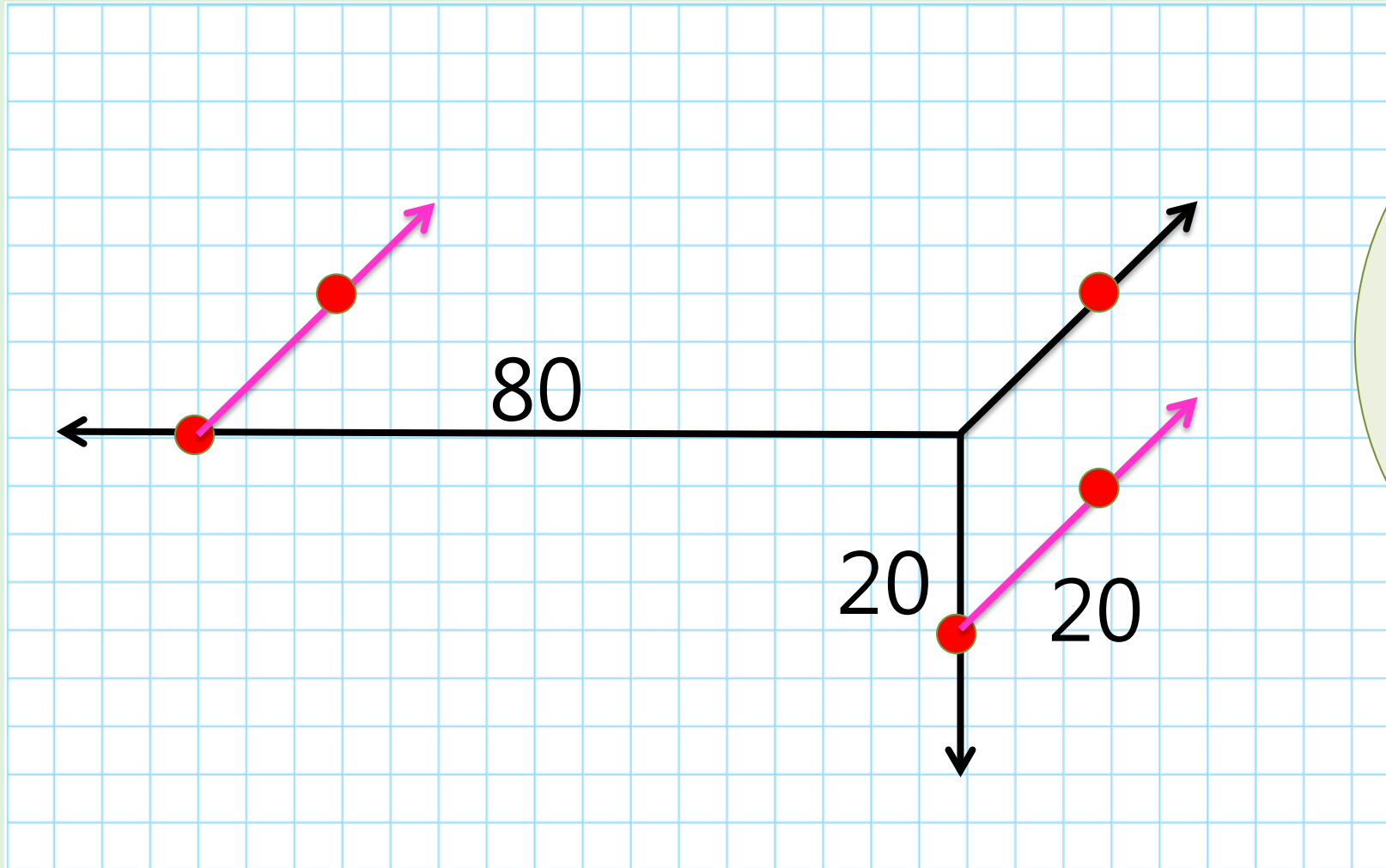

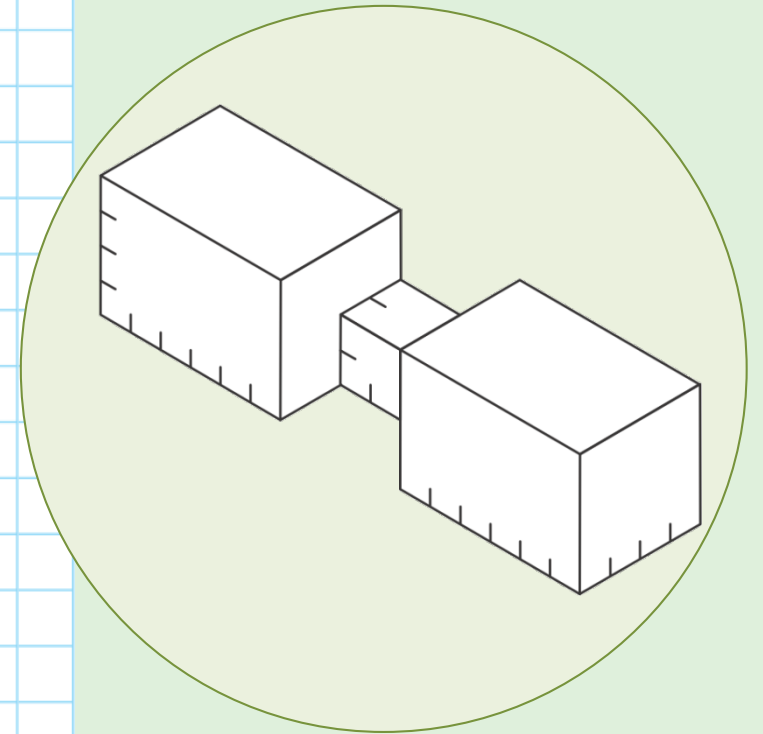
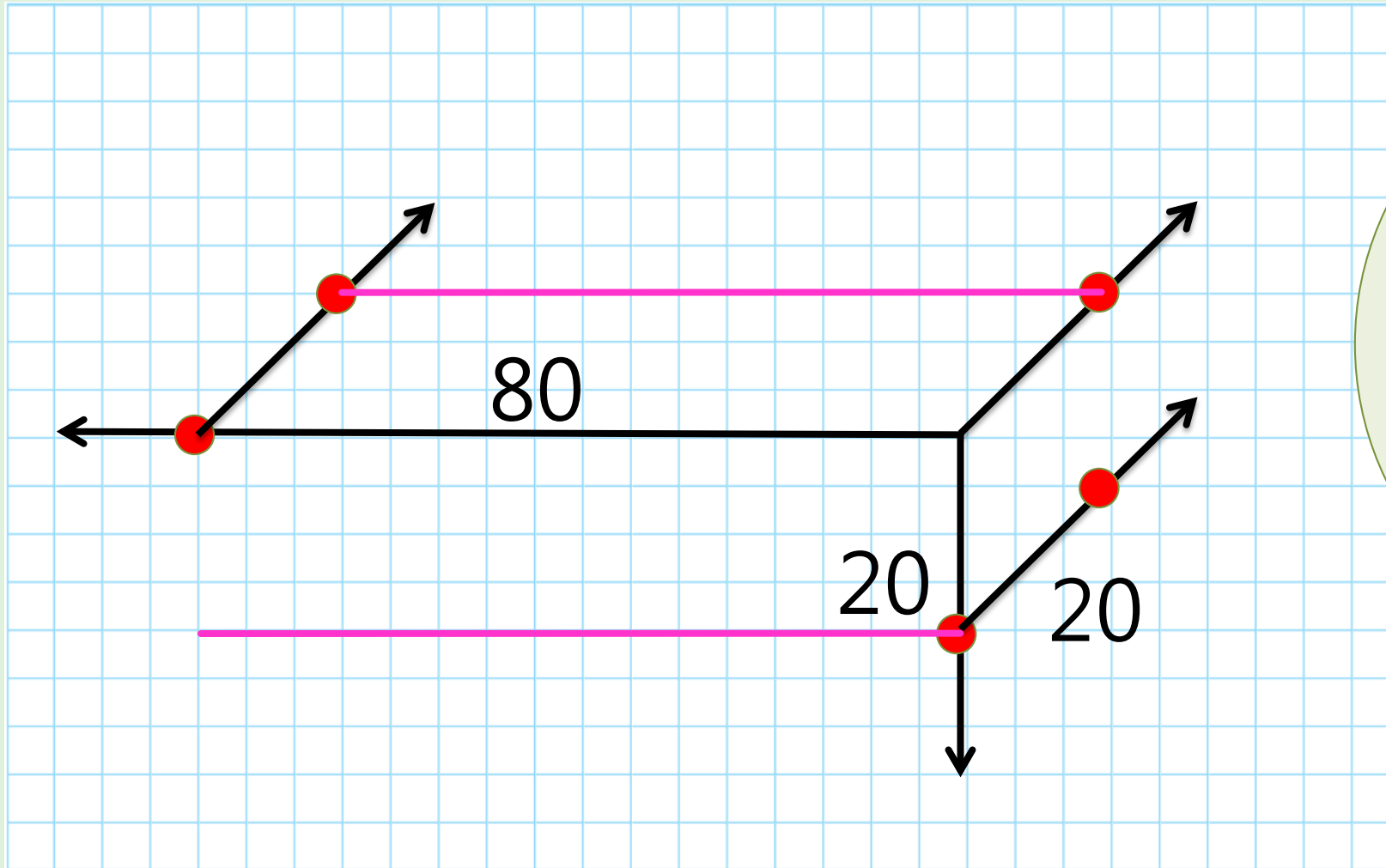

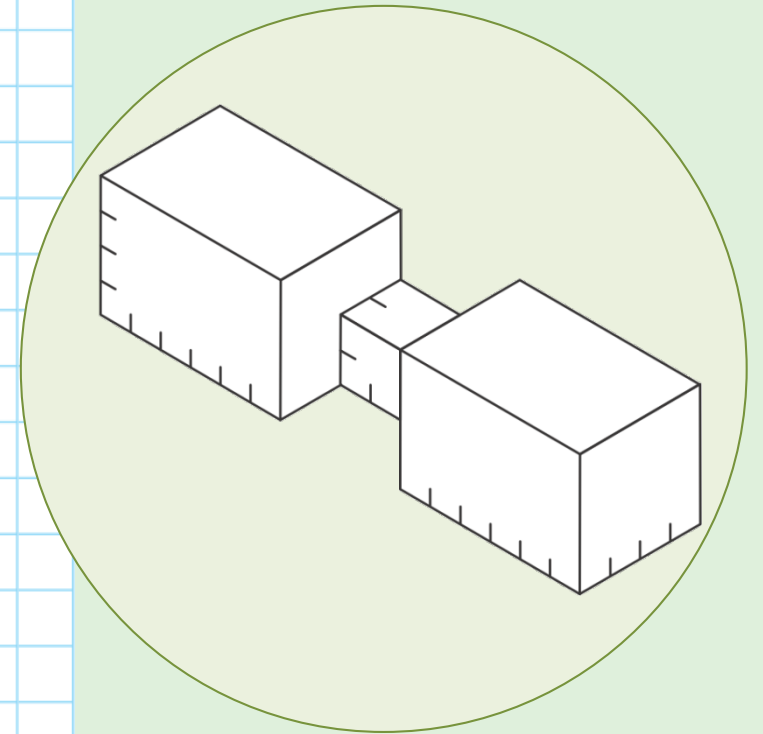
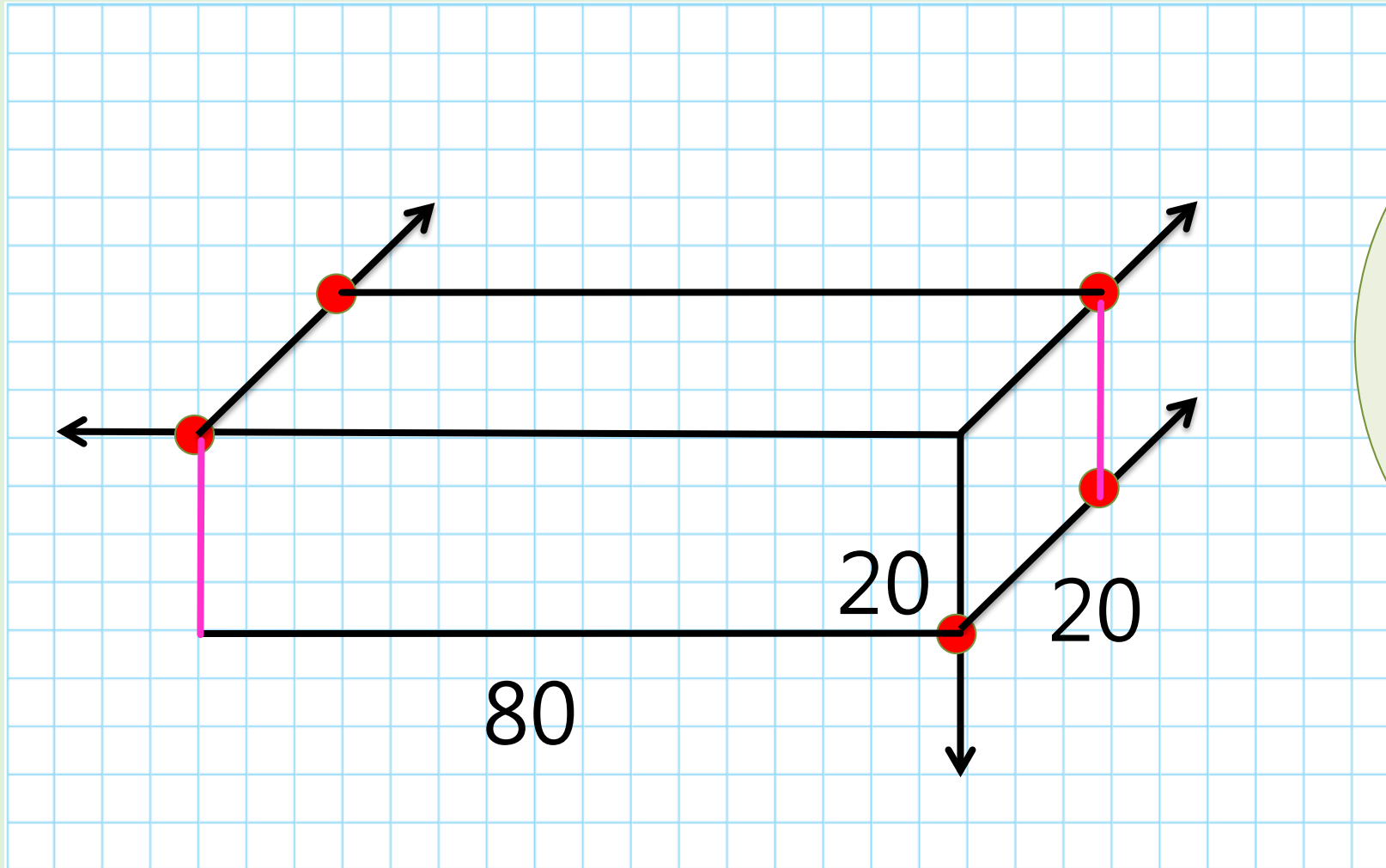

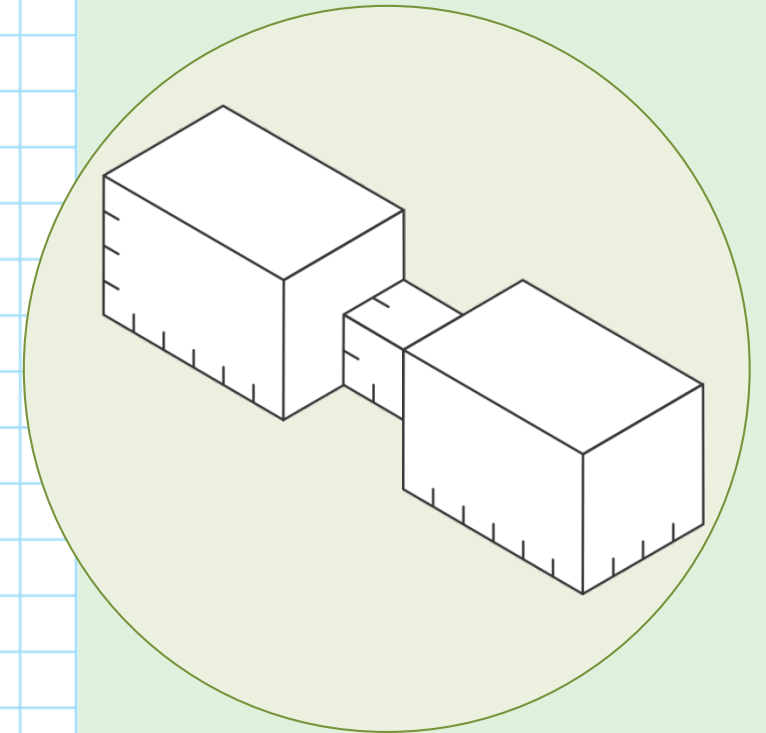
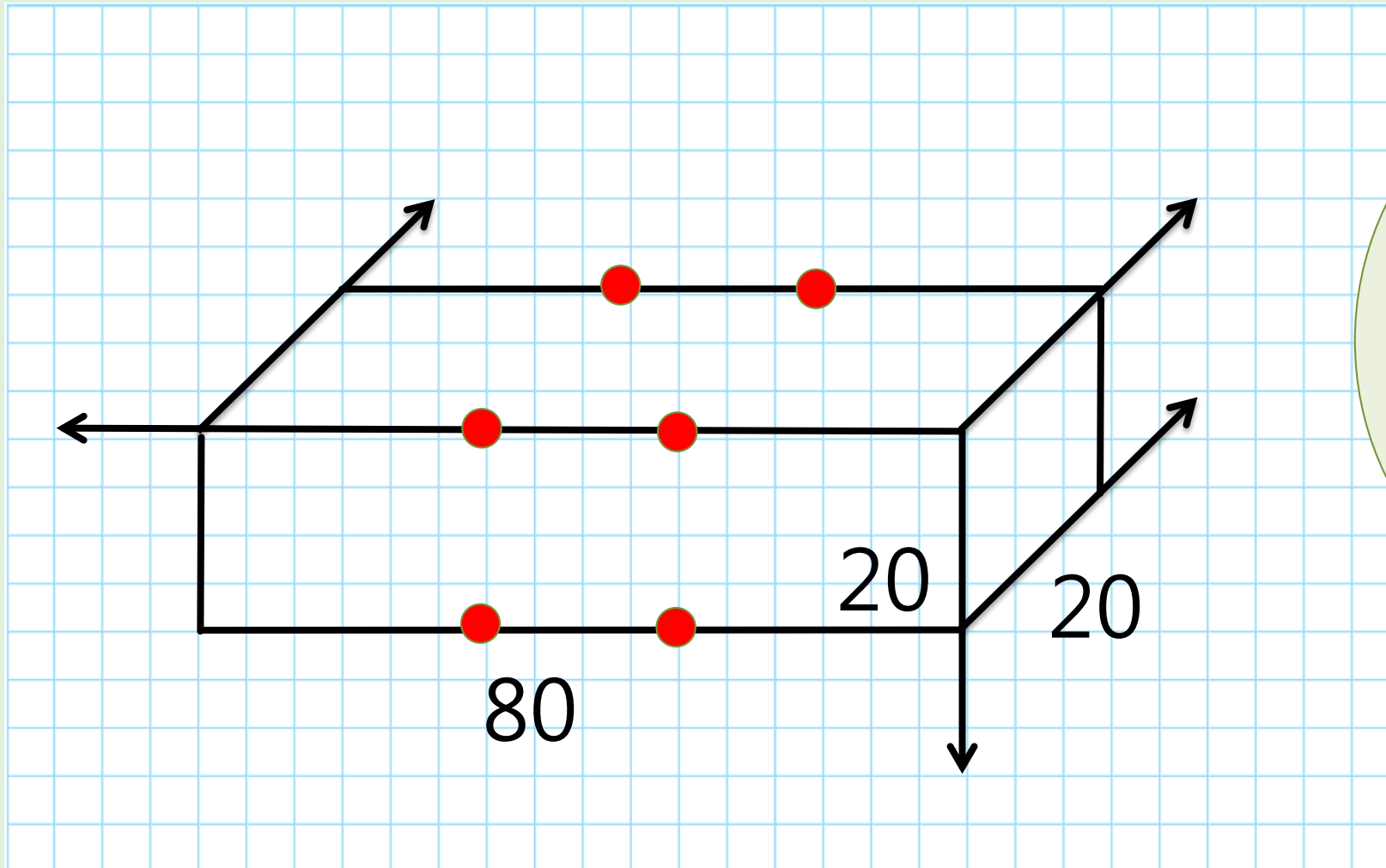

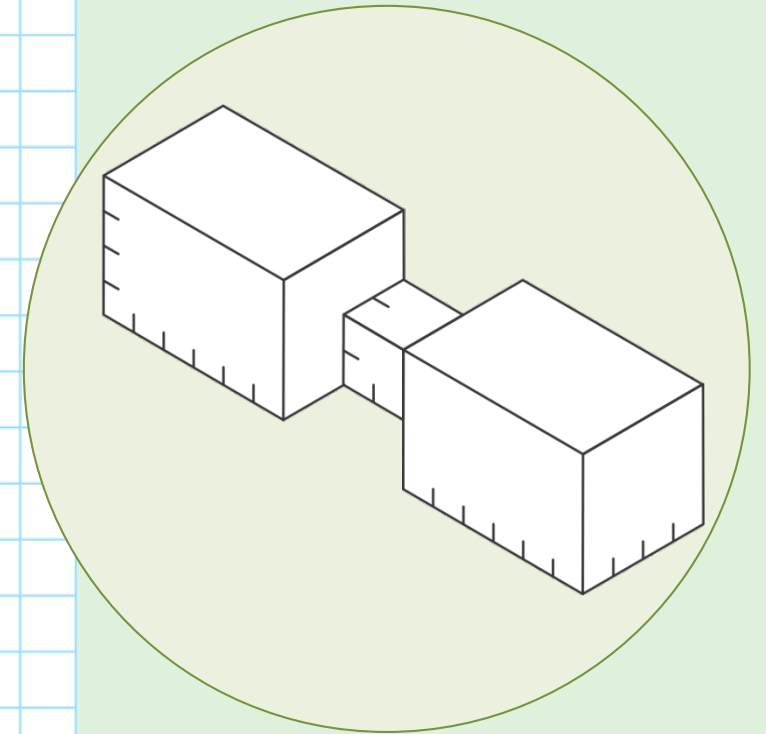
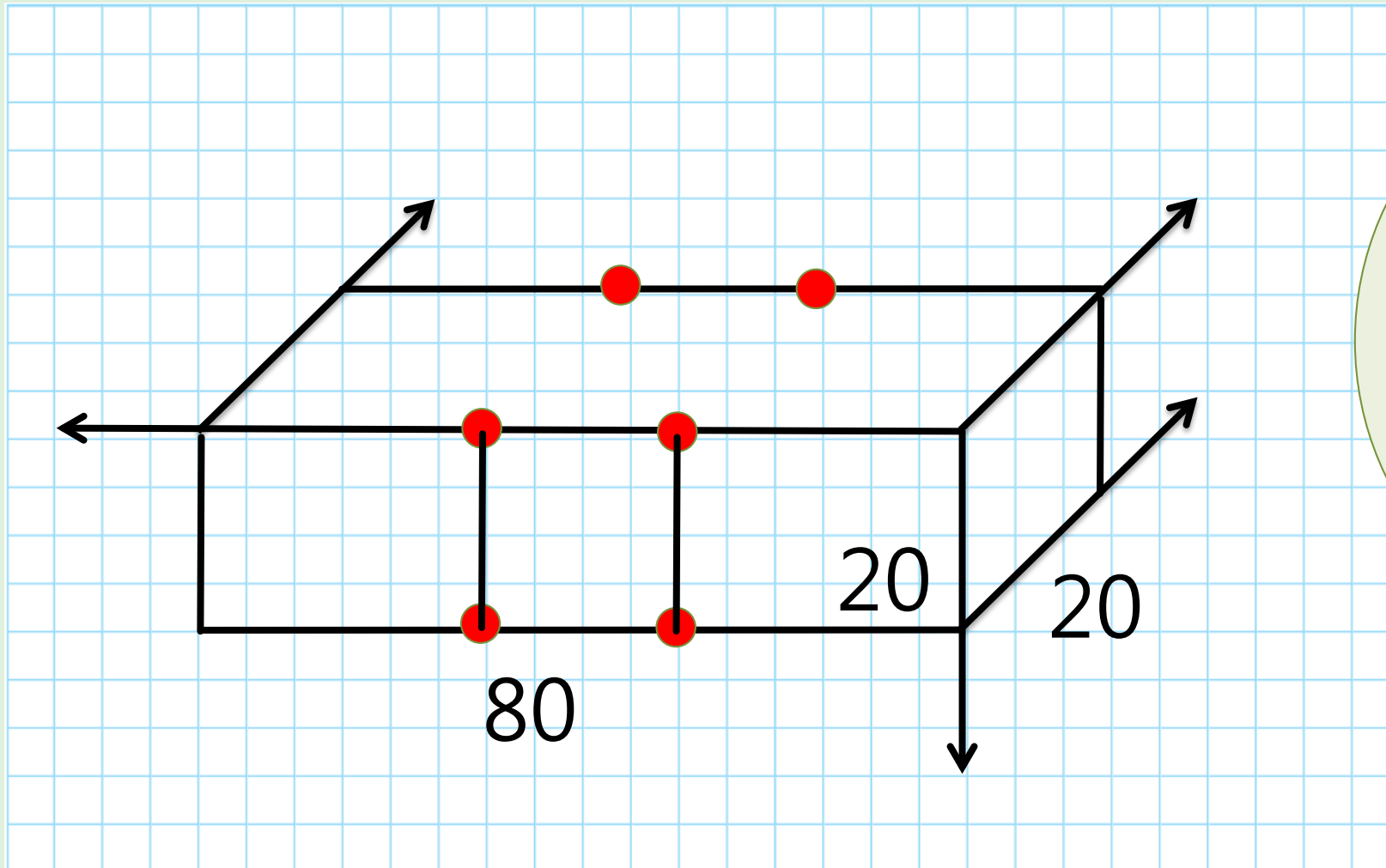

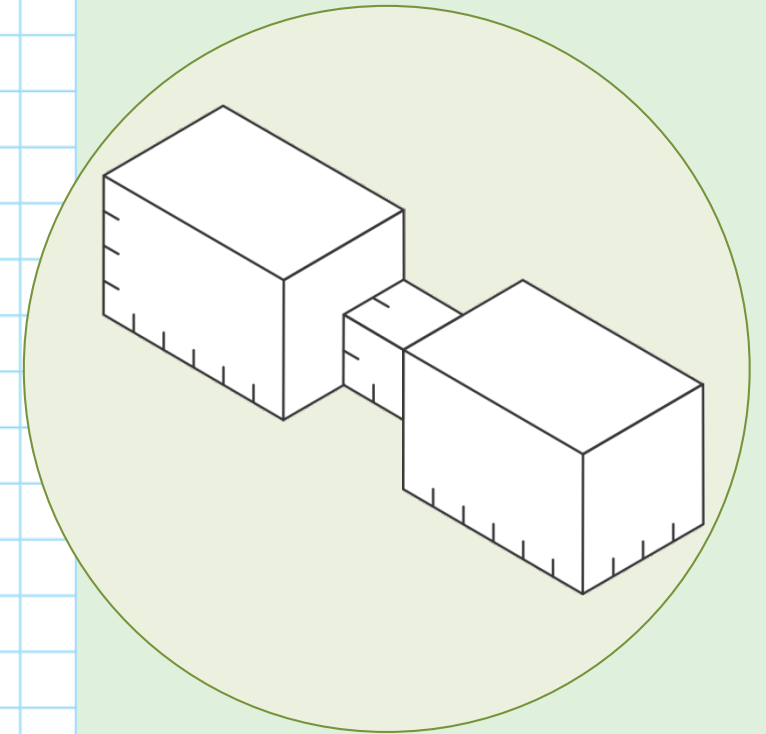
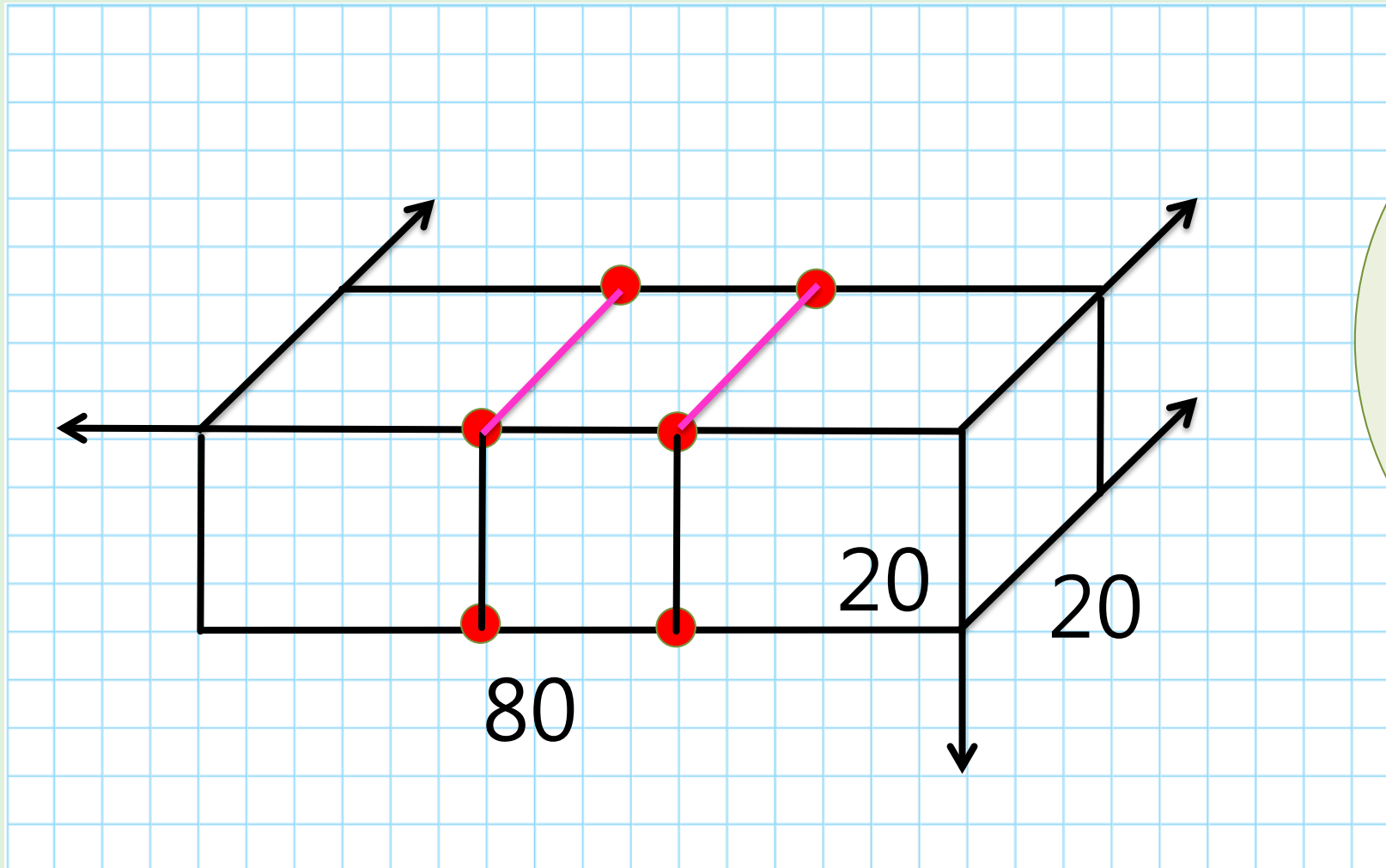

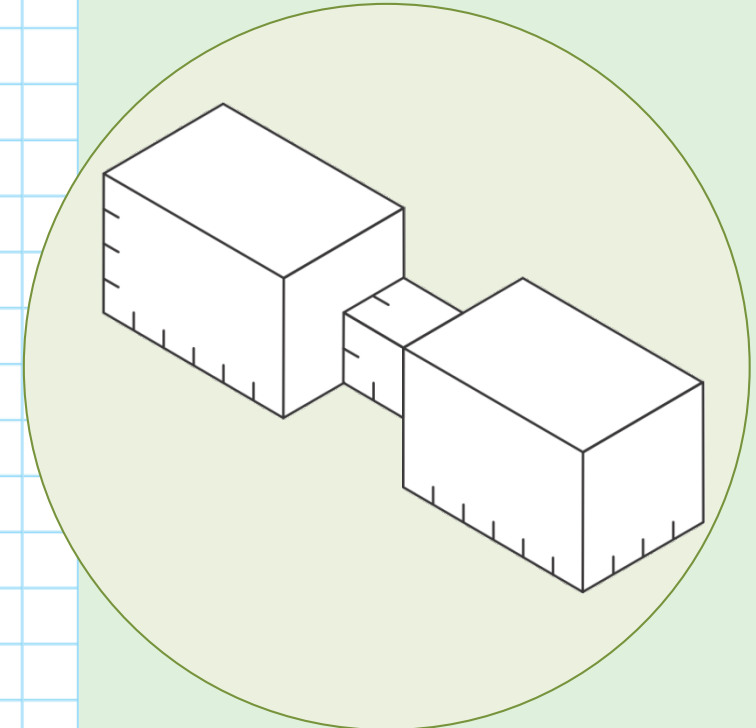
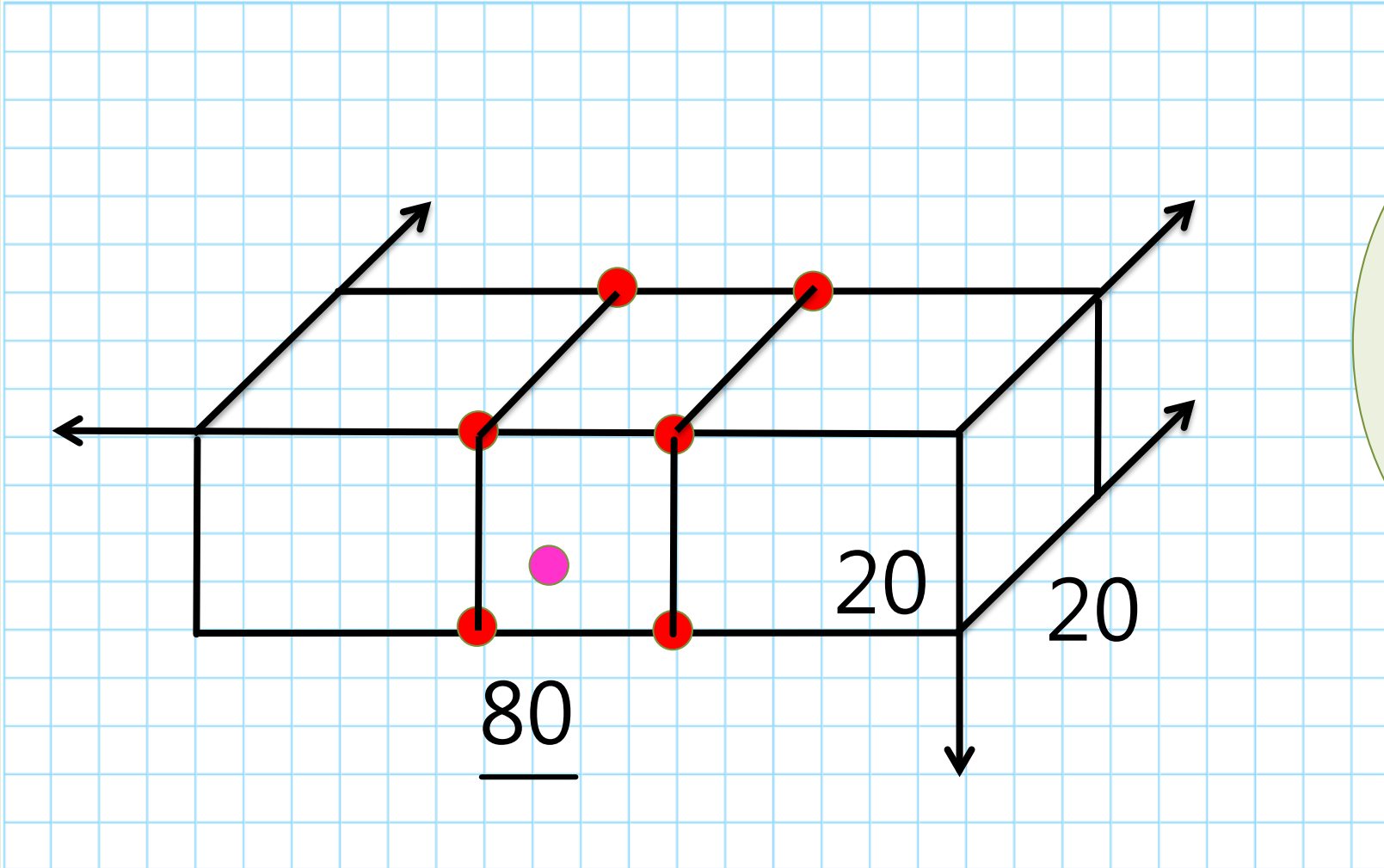

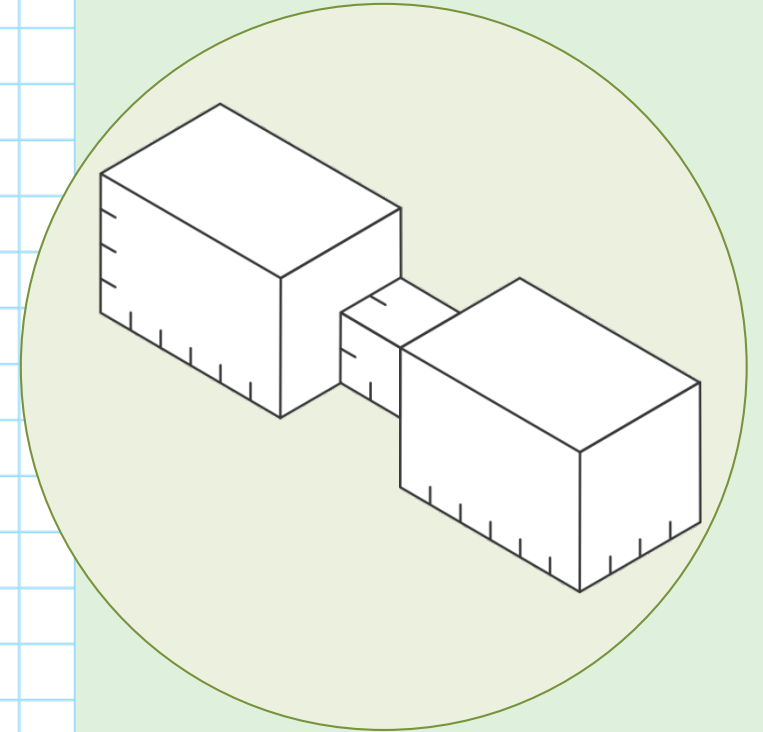
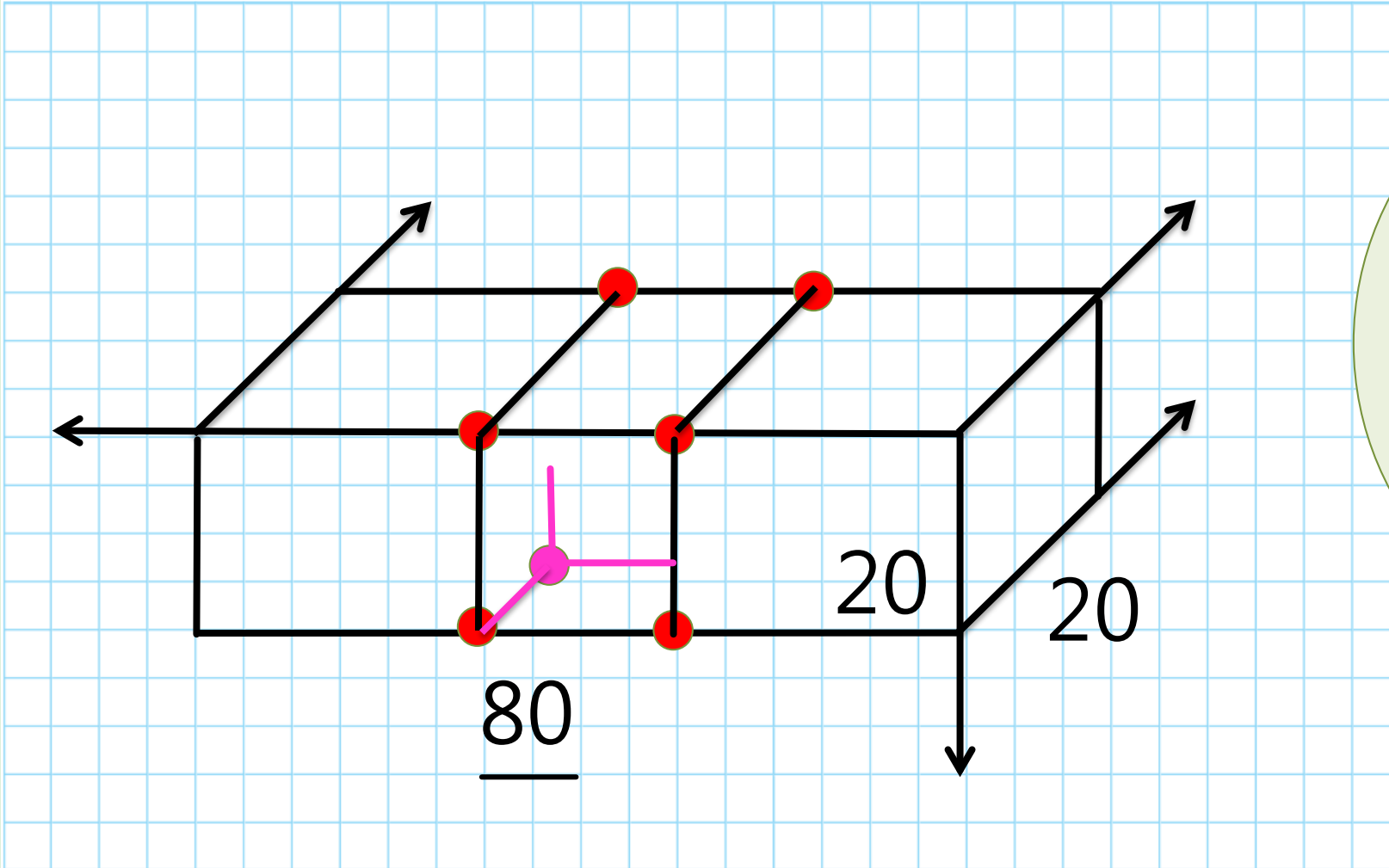

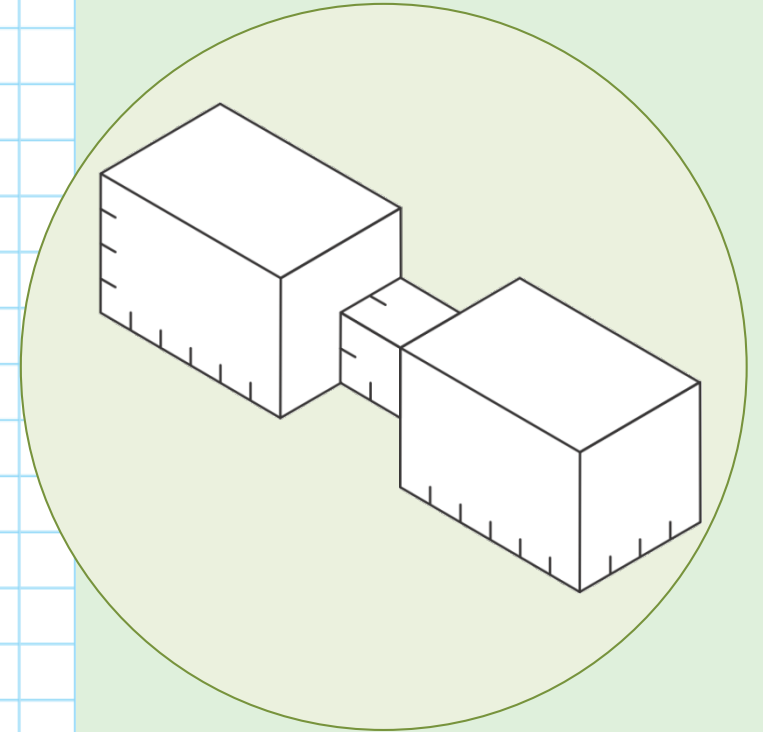
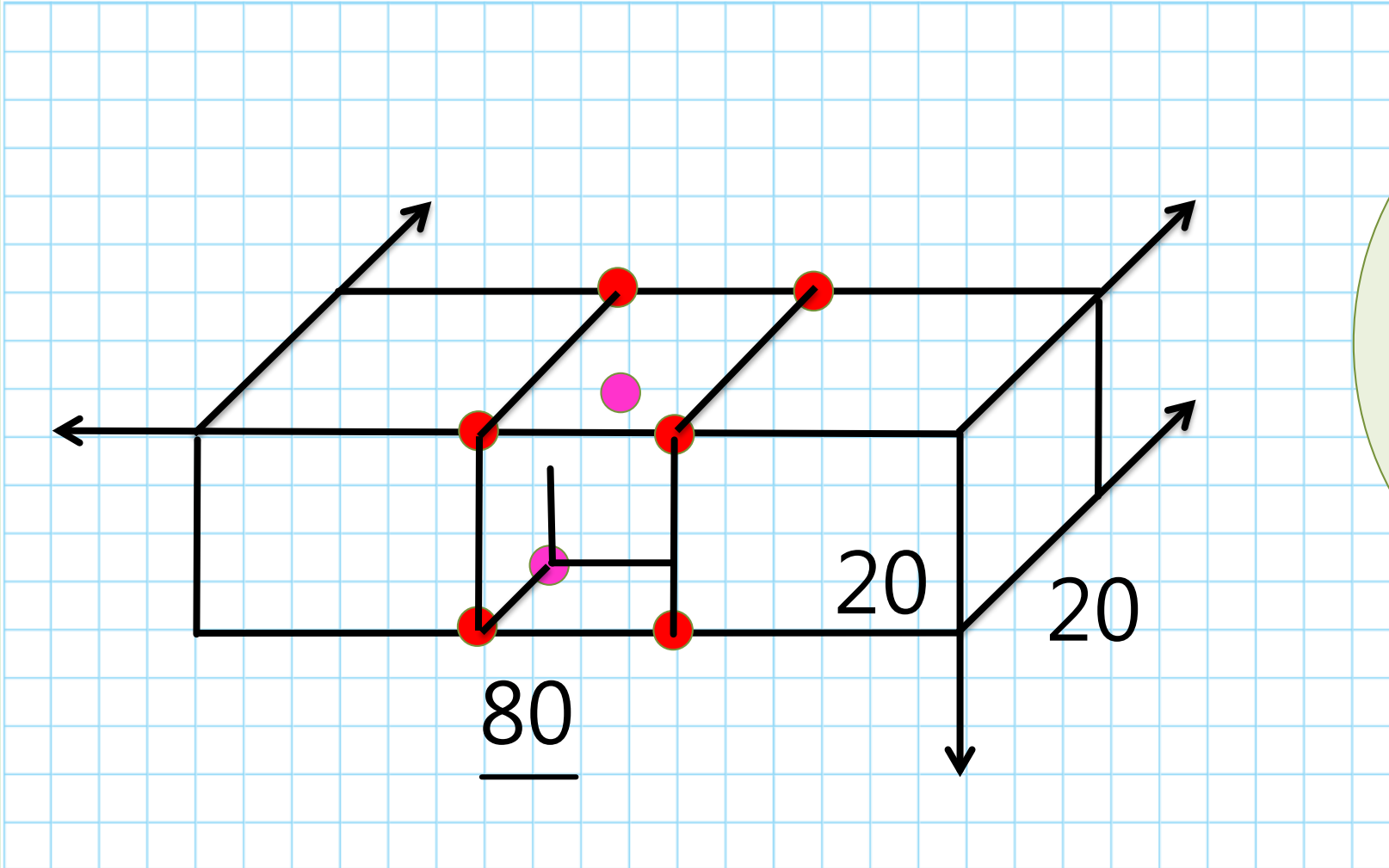

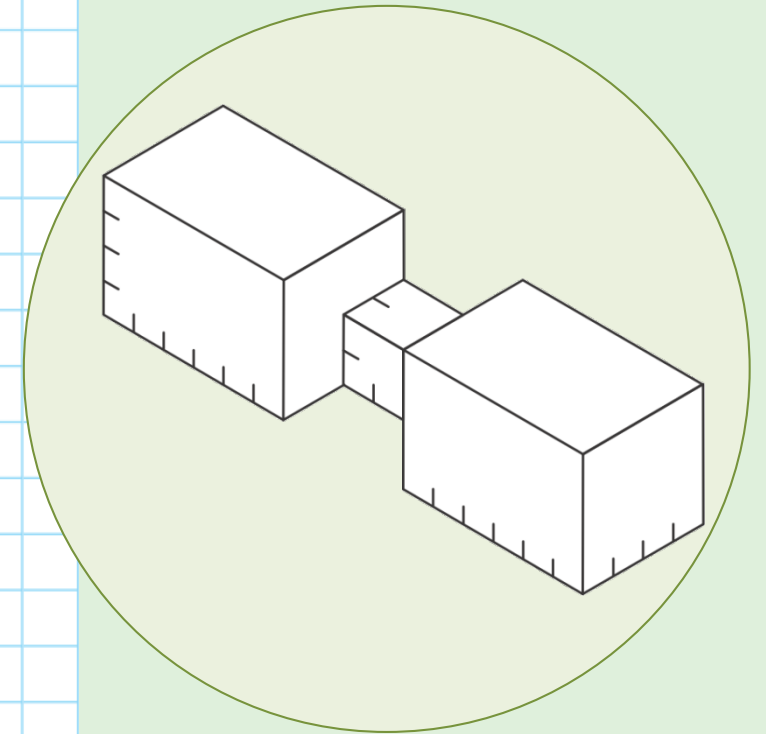
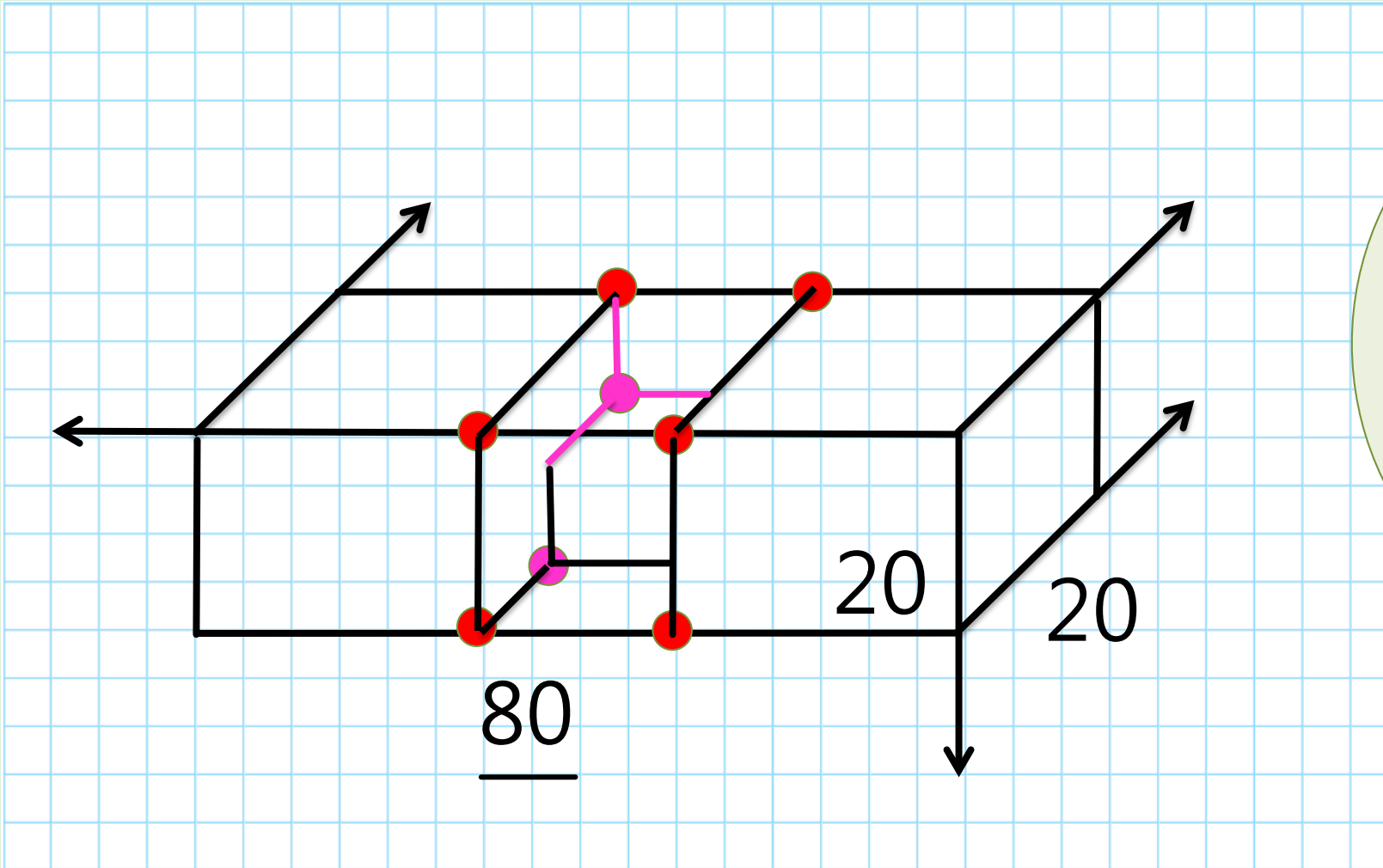

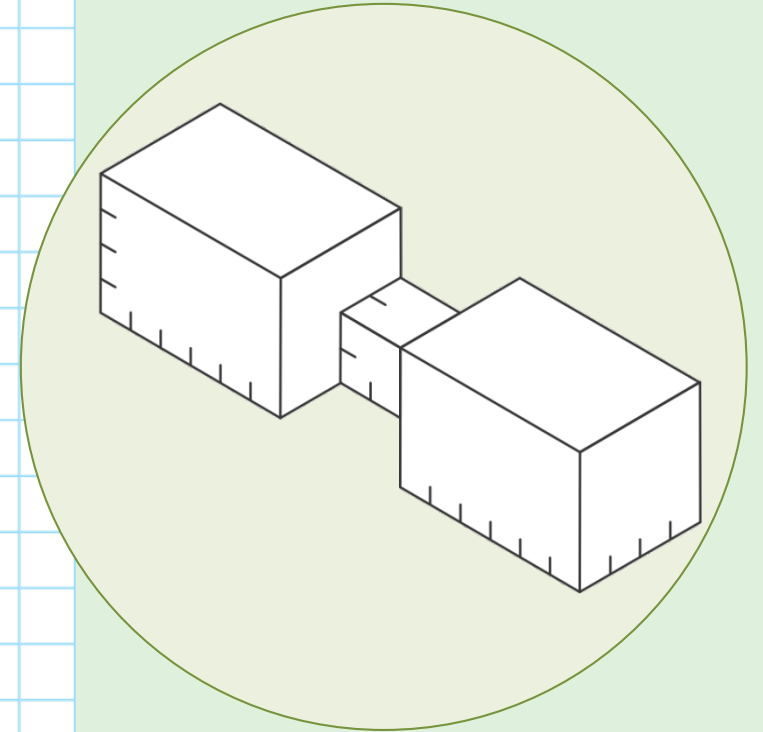
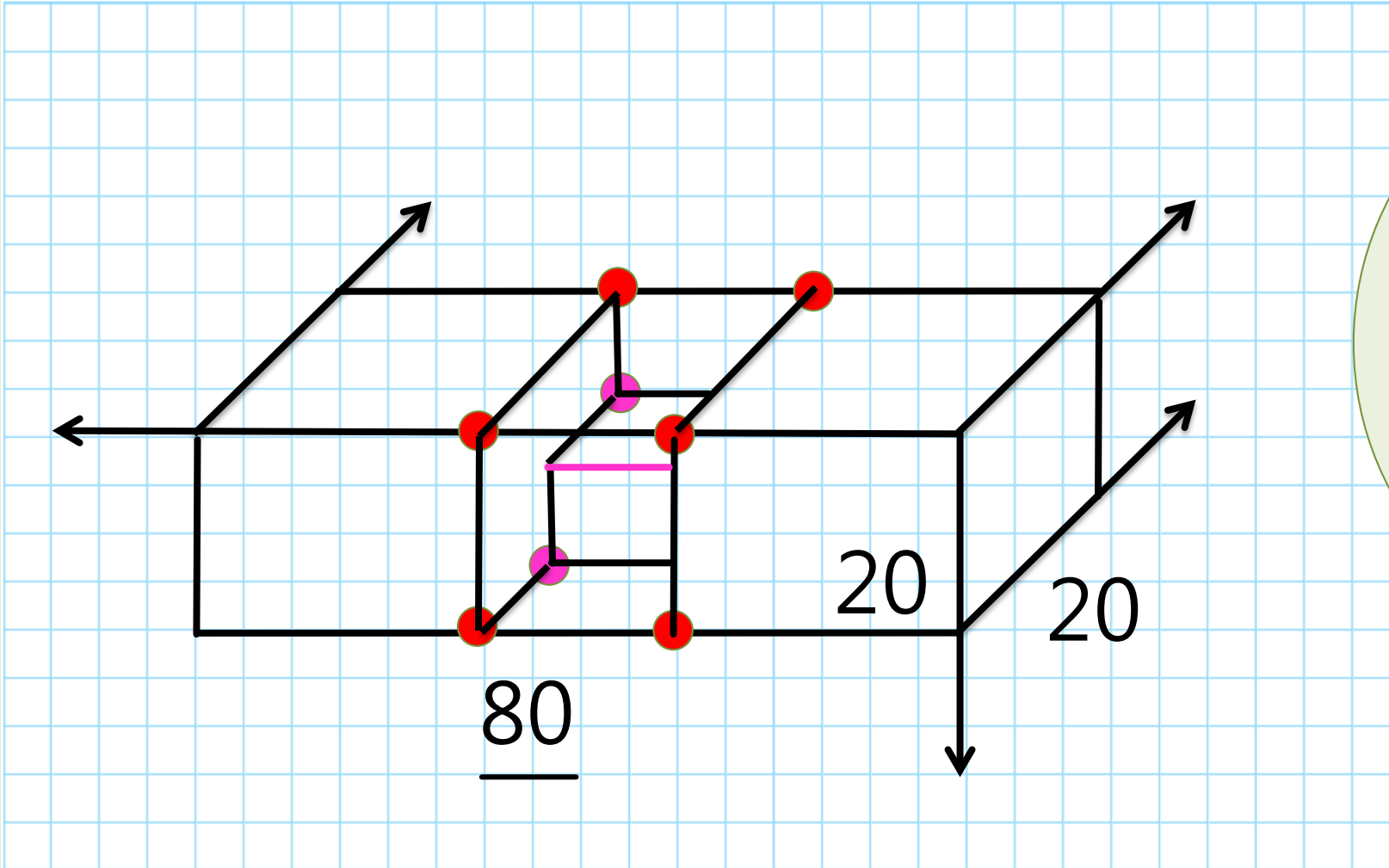

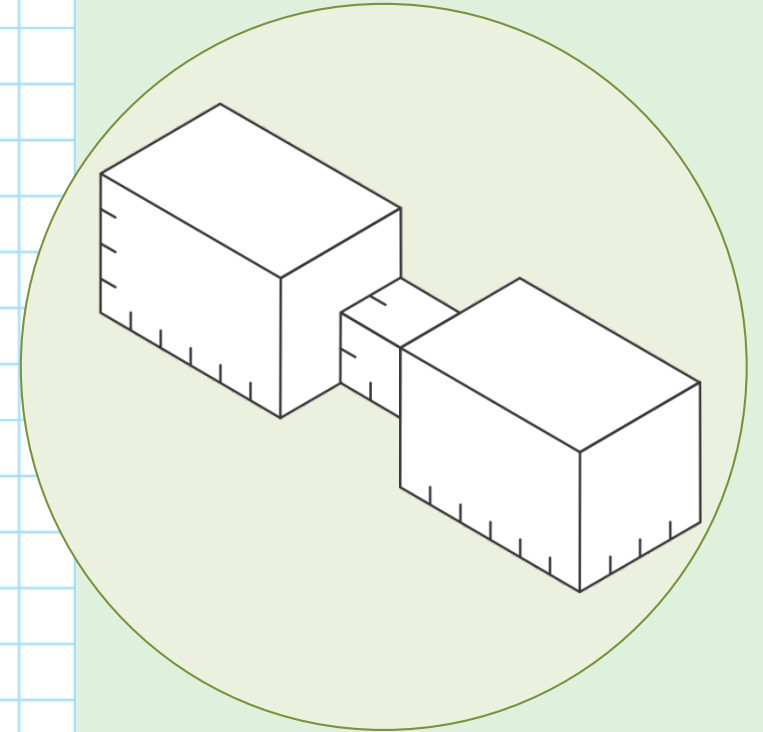
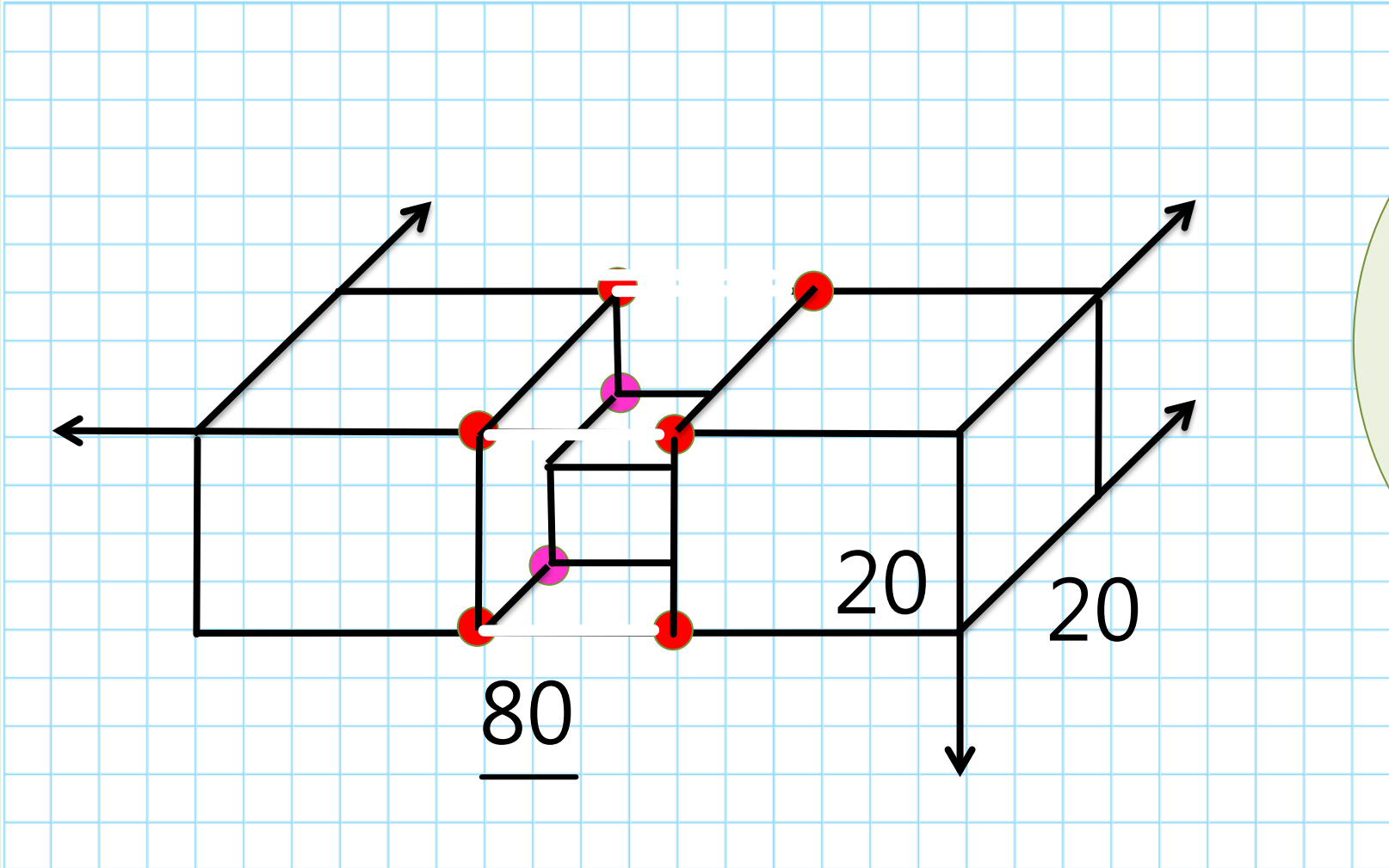

- 試試看，依據圖2-2-21繪製等角圖與等斜圖。

答

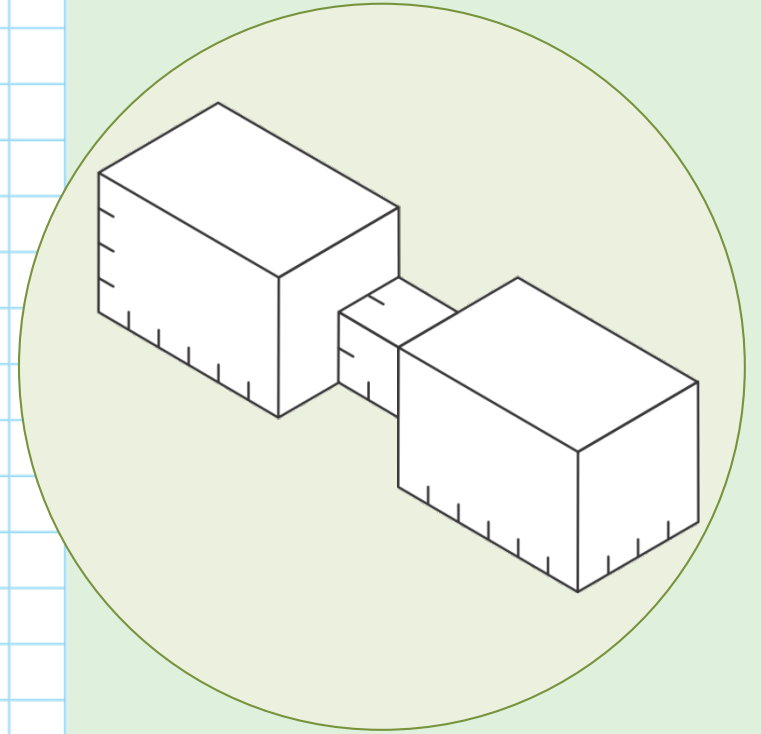
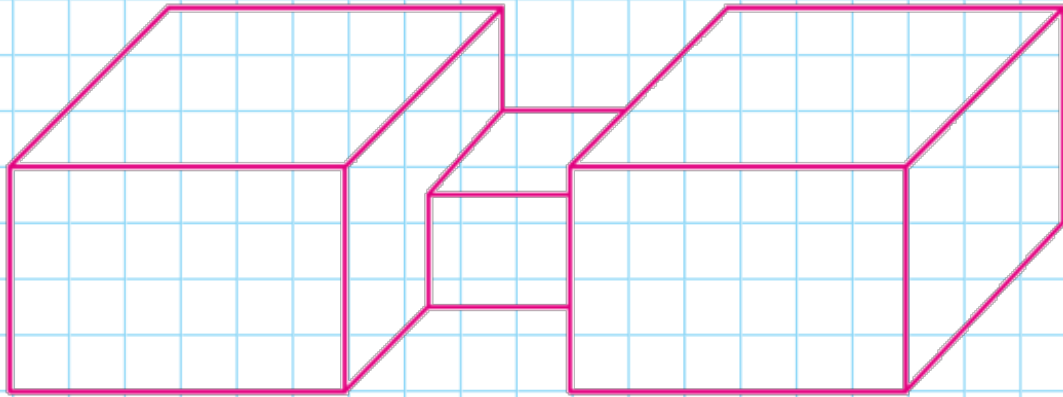

手工機具的認識與使用 學習單 七年__班 座號: __ 姓名:

○生科教室最重要的一件事是:

未經老師允許，不可擅自拿取、使用教室中的工具、材料及機器

不可在教室中跑動、飲食，活動時注意同學正在操作的事項，切記接觸碰撞...

下課離開教室前要: _____、_____、_____

1.剪刀：生活科教室常用的剪刀有：事務剪刀、園藝剪刀

(1)事務剪刀：用來剪紙或較軟的物件，剪的時候刀刃朝__，不可朝自己或將手擺在刀刃前方。

(2)園藝剪刀：用來剪竹筷子，剪的時候竹筷必須朝__。Why：

2.鉛筆、自動鉛筆

(1)鉛筆：科技教室常用的鉛筆是__、__及__，因使用過程筆芯會變粗，無法保持一定粗細，一般用來畫草圖。

鉛筆的顏色深淺和硬度，是由石墨和黏土的含量決定的，石墨的含量越高，硬度就越__，顏色越__。

硬度高低比較：5B __ 2B，HB __ 3H，5H __ 2H，4H __ 3B(填<、>)

硬度高低比較：3B __ 6B，4B __ 3H，HB __ F，F __ 2B(填<、>)

(2)自動鉛筆：科技教室常用的筆芯是__、__及__

製圖時，繪製輪廓線的粗細要求是__ mm

製圖時，繪製虛線(隱藏線)的粗細要求是__ mm

製圖時，繪製尺寸標註線、中心線(鏈線)、箭頭等的粗細要求是__ mm

3.鋼尺：

(1)鋼尺的_____ 即是刻度的起始點：0的位置(塑膠尺的起始點不在邊緣)。

(2)鋼尺的精密度是__mm，較為精密，塑膠尺的最小刻度是__mm。

(3)鋼尺的使用除了畫直線外，還可以用來檢測材料的_____。